



# 2N IP One

## User Manual



# Table of Contents

<b>Symbols and Terms Used</b> .....	<b>3</b>
<b>Product Description</b> .....	<b>4</b>
Basic Features .....	4
Product Versions .....	5
Accessories .....	5
Accessories for Installation .....	5
Extenders .....	5
Electric Locks .....	7
Power Supply .....	13
Licenses .....	13
Other accessories .....	14
Package Completeness Check .....	16
Component Layout .....	16
<b>Installation</b> .....	<b>17</b>
Mechanical Installation .....	17
General Mounting Principles .....	17
Flush mounting .....	17
Electric Installation .....	20
Power Supply .....	20
Device Connectors .....	22
LAN Connection .....	22
Overvoltage Protection .....	23
Main and Extending Modules .....	26
Module Specifications .....	26
Installation Completion .....	29
<b>Brief Guidelines</b> .....	<b>30</b>
Device Configuration Interface Access .....	30
Domain Name .....	30
IP address .....	30
Web Configuration Interface Login .....	30
IP Address Retrieval .....	31
IP Address Retrieval Using 2N Network Scanner .....	31
Dynamic/Static IP Address Switching .....	32
Device Restart .....	32
Restart Using Web Configuration Interface, .....	33
Firmware Update .....	33
Factory Default Reset .....	33
Call Connection .....	33
<b>Device Control</b> .....	<b>35</b>
<b>Troubleshooting</b> .....	<b>36</b>
<b>Technical Parameters</b> .....	<b>37</b>
<b>Directives, Laws and Regulations - General Instructions and Cautions</b> .....	<b>41</b>

## Symbols and Terms Used

The following symbols and pictograms are used in the manual:



**DANGER**

**Always abide** by this information to prevent persons from injury.



**WARNING**

**Always abide** by this information to prevent damage to the device.



**CAUTION**

**Important information** for system functionality.



**TIP**

**Useful information** for quick and efficient functionality.



**NOTE**

Routines or advice for efficient use of the device.

# Product Description

In this section, we introduce the **2N IP One** product, outline its application options and highlight the advantages following from its use.

## Basic Features

**2N IP One** is an elegant yet robust and mechanically resistant IP video intercom designed for residential buildings. It is easily interconnectable with other systems. Thanks to SIP support and compatibility with major IP PBX and phone manufacturers, it can benefit from all VoIP network services. It is available in three color versions.

### The main advantages of this device are:

**Speed Dial Button** – for this button, up to three phone numbers and call time profiles can be defined to make the called user accessible any time. The button is backlit and has a clear mechanical response.

**Robustness** – the device is designed as a robust, mechanically resistant intercom, which withstands weather conditions without needing extra accessories.

**Audio Quality**– thanks to the integrated acoustic echo cancellation (AEC) system, full duplex communication provides bilateral audibility even when the calling users are speaking at the same time.

**Device Installation** – is very easy, all you have to do is connect the system into your LAN via a network cable. The device can be supplied either from a 12 V DC power source or using PoE if supported by your LAN.

**Configuration 2N IP One** – use a PC equipped with any Internet browser for configuration.

### Other advantages of the device

- elegant design,
- adjustable button color backlight,
- weather resistance,
- sensitive microphone and speakerphone,
- bidirectional communication – acoustic echo cancellation,
- integrated color camera,
- external 12 V power supply,
- configuration via 2N My2N cloud service,
- SIP 2.0 support,
- calling option to two user accounts, each with three phone numbers,
- up to 20 user time profiles,
- video codecs (H.264, H.265, MJPEG),
- audio codecs (G.711, G.722, G.729, L16/16 kHz),
- HTTPS server for configuration,
- SMTP client for e-mail sending,
- RTSP server for video streaming,
- TFTP/HTTP client for automated configuration update.

## Product Versions



**Part No. 9158104**

Axis Part No. 02933-001

2N IP One Main Unit – Gray



**Part No. 9158106**

Axis Part No. 02935-001

2N IP One Main Unit – Black

We do not recommend installation in places exposed to direct sunlight.



**Part No. 9158105**

Axis Part No. 02934-001

2N IP One Main Unit – Bronze

## Accessories

### Accessories for Installation

2N IP One is designed for outdoor applications and requires no additional roof.

Choose the proper a mounting box depending on your particular installation needs.



**Part No. 9158001**

Axis Part No. 02941-001

Flush Mounting Box

The flush mounting box is used for connection and storage of cables below the device.

## Extenders

## Product Description

### **Part No. 9159010**

Axis Part No. 01386-001

Security Relay



A handy add-on that significantly enhances security. It prevents lock tampering.

To be installed between the protected device from which it is also powered and the lock controlled by it.

## Electric Locks



### Part No. 11202101

Electric opener Mini 5 series – short

The electric opener is designed for door frame installation, especially for such narrow profiles as aluminum, wooden or PVC frames

Features:

- short sheet metal front cover version (130 mm)
  - 16 mm width
- 



### Part No. 11202101-L

Electric opener Mini 5 series – long

The electric opener is designed for door frame installation, especially for such narrow profiles as aluminum, wooden or PVC frames

Features:

- long sheet metal front cover version (250 mm)
  - 16 mm width
- 



### Part No. 11202102

Electric opener Mini 5 series with door hold in open state – short

The electric opener is designed for door frame installation, especially for such narrow profiles as aluminum, wooden or PVC frames

Features:

- short sheet metal front cover version (130 mm)
  - 16 mm width
- 



### Part No. 11202102-L

Electric opener Mini 5 series with door hold in open state – long

The electric opener is designed for door frame installation, especially for such narrow profiles as aluminum, wooden or PVC frames

Features:

- long sheet metal front cover version (250 mm)
  - 16 mm width
-

## Product Description

### Part No. 11202103



Electric opener Mini 5 series with mechanical blocking – short

The electric opener is designed for door frame installation, especially for such narrow profiles as aluminum, wooden or PVC frames

Features:

---

### Part No. 11202103-L



Electric opener Mini 5 series with mechanical blocking – long

The electric opener is designed for door frame installation, especially for such narrow profiles as aluminum, wooden or PVC frames

Features:

- long sheet metal front cover version (250 mm)
  - 16 mm width
- 

### Part No. 11202104



Electric opener Mini 5 series with monitoring – short

The electric opener is designed for door frame installation, especially for such narrow profiles as aluminum, wooden or PVC frames

Including a door state monitoring micro switch – open/closed.

Features:

- short sheet metal front cover version (130 mm)
  - 16 mm width
- 

### Part No. 11202104-L



Electric opener Mini 5 series with monitoring – long

The electric opener is designed for door frame installation, especially for such narrow profiles as aluminum, wooden or PVC frames

Including a door state monitoring micro switch – open/closed.

Features:

- long sheet metal front cover version (250 mm)
  - 16 mm width
-



## Product Description

### Part No. 11202105



Electric fail safe opener Mini 5 series with mechanical blocking – short

The electric opener is designed for door frame installation, especially for such narrow profiles as aluminum, wooden or PVC frames

Under voltage, the opener is secured, i.e. blocked, once voltage is stopped, the opener is unblocked and the door can be opened.

Features:

- short sheet metal front cover version (130 mm)
  - 16 mm width
- 

### Part No. 11202105-L



Electric fail safe opener Mini 5 series with mechanical blocking – long

The electric opener is designed for door frame installation, especially for such narrow profiles as aluminum, wooden or PVC frames

Under voltage, the opener is secured, i.e. blocked, once voltage is stopped, the opener is unblocked and the door can be opened.

Features:

- long sheet metal front cover version (250 mm)
  - 16 mm width
- 

### Part No. 11202106



Electric fail safe opener Mini 5 series with monitoring – short

The electric opener is designed for door frame installation, especially for such narrow profiles as aluminum, wooden or PVC frames

Under voltage, the opener is secured, i.e. blocked, once voltage is stopped, the opener is unblocked and the door can be opened.

Features:

- short sheet metal front cover version (130 mm)
  - 16 mm width
- 

### Part No. 11202106-L



Electric fail safe opener Mini 5 with monitoring – long

The electric opener is designed for door frame installation, especially for such narrow profiles as aluminum, wooden or PVC frames

The electric opener is fully reversible and highly resistant.

Under voltage, the opener is secured, i.e. blocked, once voltage is stopped, the opener is unblocked and the door can be opened.

## Product Description

### Features:

- long sheet metal front cover version (250 mm)
  - 16 mm width
- 



### Part No. 11202201

#### Electromechanical lock SAM 7255

The self-locking 72/55 lock with panic function is a suitable solution for emergency exits. A key is necessary to open the door from the outside (or an electric pulse from a connected 2N IP intercom/reader).

---



### Part No. 11202201-M

#### Electromechanical lock SAM 7255 with monitoring

The self-locking 72/55 lock with panic function is a suitable solution for emergency exits. A key is necessary to open the door from the outside (or an electric pulse from a connected 2N IP intercom/reader).

---



### Part No. 11202202

#### Electromechanical lock SAM 9235

The self-locking 92/35 lock with panic function is a suitable solution for emergency exits. A key is necessary to open the door from the outside (or an electric pulse from a connected 2N IP intercom/reader).

---



### Part No. 11202202-M

#### Electromechanical lock SAM 9235 with monitoring

The self-locking 92/35 lock with panic function is a suitable solution for emergency exits. A key is necessary to open the door from the outside (or an electric pulse from a connected 2N IP intercom/reader).

---



### Part No. 11202301

#### Cable bushing FX290

Provides secure passage and protection of the power cable between the door frame and the door wing.

### Features:

- 290 mm length
-

## Product Description



### **Part No. 11202302**

Cable bushing FX510

Provides secure passage and protection of the power cable between the door frame and the door wing.

Features:

- 510 mm length



### **Part No. 11202303**

Cable protector FX300G

Provides secure passage and protection of the power cable between the door frame and the door wing.

Features:

- 440 mm length



### **Part No. 11202304**

Cable protector FX500G

Provides secure passage and protection of the power cable between the door frame and the door wing.

Features:

- 640 mm length



### **Part No. 11202107**

Electromagnetic lock MEX100

Used as a door holding supplement, not replacing the lock.

It consists of two parts:

- powered part
- counterpart

The door cannot be opened under voltage. Once voltage is disconnected, the magnets release and the door opens.

## Product Description



### **Part No. 11202501**

Magnetic handle P300RP

The magnetic handle fully replaces a mortise lock and a door handle.

The door cannot be opened under voltage. Once voltage is disconnected, the magnets release and the door opens.

Suitable for wooden, metal and glass doors.



### **Part No. 11202401**

Automatic opener ED100

Low-energy, simple automatic machine for a fully contactless operation.

Interconnectable with a motion sensor and electronic access control system. Can be used both for the right and left doors and is available in the IN/OUT opening design.



#### **TIP**

FAQ: [Electric locks – Differences between locks for 2N IP access systems](#)

## Power Supply



**Part No. 91341481E (with EU cable)**

**Part No. 91341481US (with US cable)**

Axis Part No. 02520-001

Stabilized 12 V / 2 A power supply

The supply must be used where PoE is not used.

---



**Part No. 932928**

Axis Part No. 02529-001

12 V transformer

For 230 V mains voltage.

Designed for external supply of electric locks.

---



**Part No. 9159052**

Axis Part No. 01393-001

12 V / 1 A power supply for 2N Induction Loop

The external induction loop power supply has 230 V AC input voltage and 12 V DC output voltage.

---

## Licenses



**Part No. 9137909**

Axis Part No. 01380-001

Gold License

Includes the Enhanced Video, Enhanced Integration and Lift Control licenses.

---



**Part No. 9137910**

Axis Part No. 01381-001

InformaCast License

**Other accessories**

## Product Description

### Part No. 9159013



Axis Part No. 02523-001

Departure button

The departure button is connected to the device logic input for opening the door from inside the building.

---

### Part No. 9159012



Axis Part No. 01388-001

Magnetic door contact

Set for installation on a door, enabling the status of door opening to be ascertained. Used where the device is used for door protection, open door detection or forced opening.

---

### Part No. 9137410E



Axis Part No. 01397-001

External IP relay, 1 output

Stand-alone relay, which can be controlled from an IP intercom via HTTP commands and helps control devices from an unlimited distance.

---

### Part No. 9159014EU/US/UK



Axis Part No. 01404-001

2N 2Wire (set of 2 adaptors and power source for EU/US/UK)

The 2N 2Wire converter allows you to use the existing 2-wire cabling from your original doorbell or door intercom for connecting any IP device. You do not have to configure anything, all you need is one 2N 2Wire unit at each end of the cable and a power supply connected to at least one of these units. The 2N 2Wire unit then provides PoE power not only to the second converter, but to all of the connected IP end devices.

---

### Part No. 1120103/1120103EU



Axis Part No. 02318-001

NVT PoLRE LPC Switch

The switch provides an IP solution with analog cabling.

The package includes 2 SIP adapters. Additional adapters can be ordered, Part No. **1120104**.

---

## Product Description

### Part No. 1120104

Axis Part No. 02319-001

NVT PhyLink Adapter

SIP adapter for switch use, Part No. **1120103**.

The package includes 6 pieces.



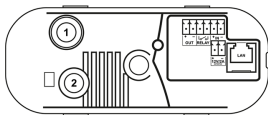
## Package Completeness Check

Please check the product delivery before installation. Contents:

1x	<b>2N IP One</b>
1x	Certificate of ownership
1x	Quick Start manual
1x	connector plate
3x	Torx head screw
1x	Torx wrench

## Component Layout

**2N IP One** is equipped with the following buttons on its backside:



1. Tamper Switch  
The purpose of the tamper switch is to signal any unauthorized opening of the intercom (to prevent a theft, e.g.).
2. CONTROL button  
Used for resetting the default factory values.



# Installation

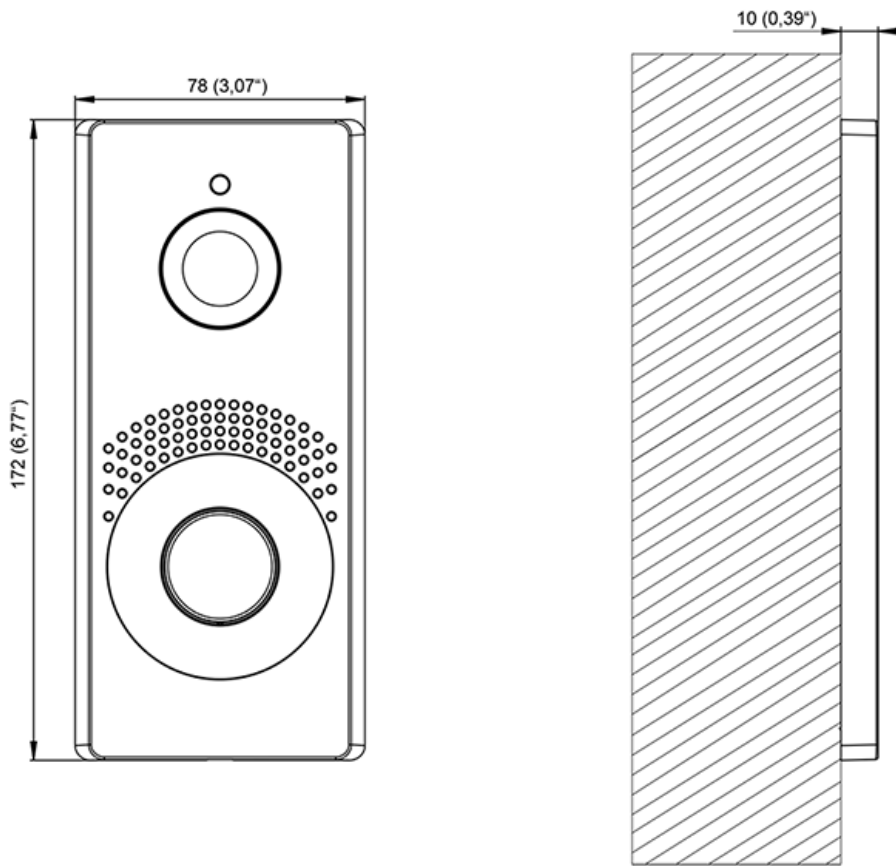
## Mechanical Installation

### General Mounting Principles

- Before starting the mechanical installation on a selected place, make sure carefully that the preparations associated with it (drilling, wall cutting) cannot damage the electrical, gas, water and other existing wires and pipes.
- The warranty does not apply to the product defects and failures arisen as a result of improper installation (in contradiction herewith). The manufacturer is neither liable for damage caused by theft within an area that is accessible after the attached electric lock is switched on. The product is not designed as a burglar protection device except when used in combination with a standard lock, which has the security function.
- When the proper installation instructions are not met, water might get in and destroy the electronics. As the device circuits are constantly under voltage water leakage causes electrochemical reaction. The manufacturer's warranty shall be void for products damaged in this way!
- Make sure that the dowel holes have the required diameter. If the diameters are too large, the dowels may get loose! Use the mounting glue to secure the dowels if necessary.
- Make sure that the depths of the dowel holes are accurate!
- Do not use low-quality dowels to avoid their falling out of the wall!
- Having removed the front panel, make sure that no dirt gets inside the product, especially onto the sealing surface.
- Make sure that the plasterboard interior does not show a pressure value significantly different from that of the room, e.g. that it is not connected with overpressure ventilation. If the difference is too great, separate the device in terms of pressure (using, e.g., a mounting box) and seal the cable passage.

### Flush mounting

The flush mounting box allows you to place cables in the wall below **2N IP One** and mount the device.



What you need for mounting:

- **2N IP One**
- Flush mounting box (Part No. **9158001**)

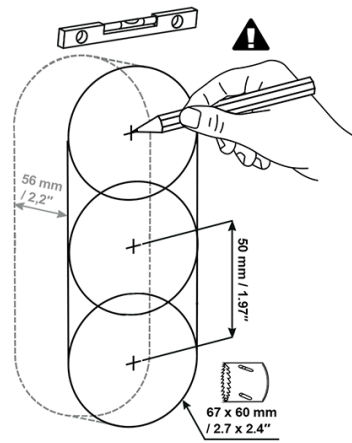


**WARNING**

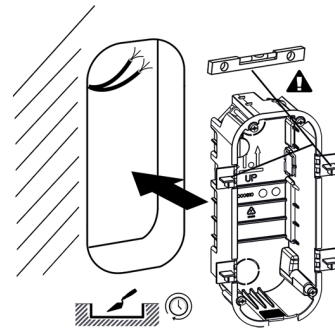
Before starting the mechanical installation on a selected place, make sure carefully that the preparations associated with it (drilling, wall cutting) cannot damage the electrical, gas, water and other existing wires and pipes.

# Installation

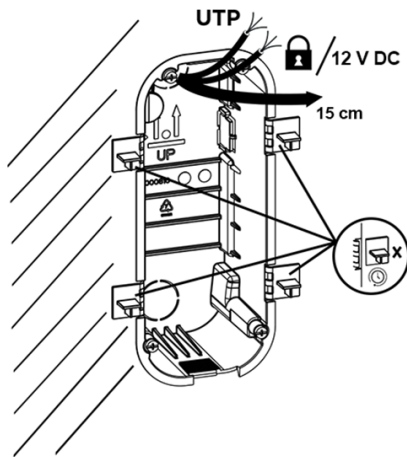
1.



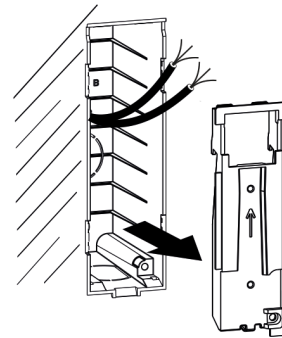
2.



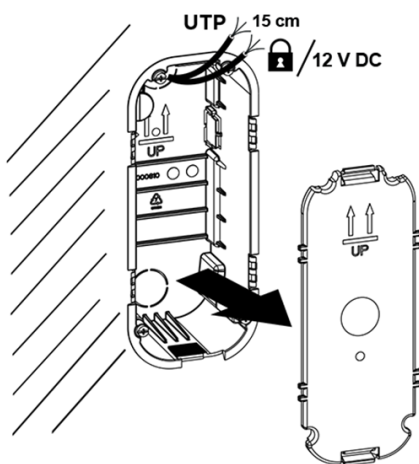
3.



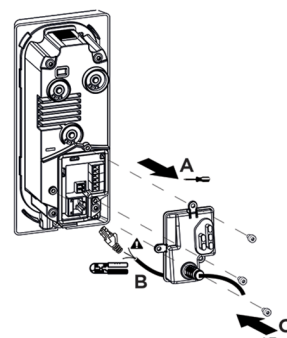
4.



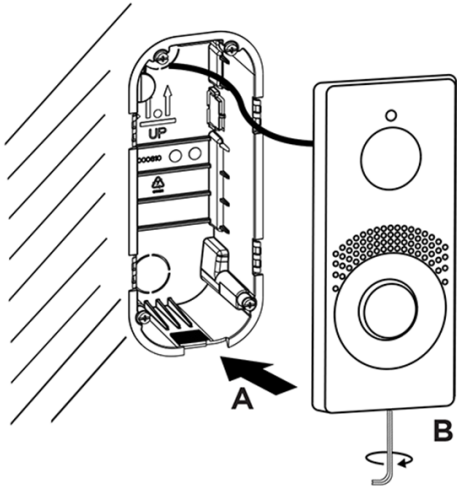
5.



6.



7.



1. Cut a hole in the wall. The recommended hole depth is 56 mm.



**TIP**

Download the drilling template from [2N.com](http://2N.com).

2. Remove one of the blinds on the plastic box and pull the cables through. The recommended length of the accessible cables is 15 cm. Mind the two arrows engraved on the box bottom and the included blind to keep the proper installation orientation. Place the box into the wall hole. Use the four side bosses to determine the proper depth of the flush mounting. Use a walling material of your choice.
3. Use the four side bosses to determine the proper depth of the flush mounting. Make sure that the box edges are aligned with the wall after finishing the masonry. Break off the bosses after the walling material hardens.
4. Close the box with a blank. This prevents the walling and surfacing dirt from getting into the box surroundings.
5. Let the walling material harden after finishing the masonry and wall surfacing and remove the blank.
6. The package includes an L-shaped plastic plate and 3 Torx head screws. Cut 1–2 mm off the upper part of the cylinder-shaped rubber on the plate. Pull the cable through the remaining part. Use a crimping tool to crimp the cable connector and insert it in the terminal. Cover the terminal space with a plate and screw it.



**WARNING**

Keep the maximum tightening torque of 0.5 Nm.

7. Insert the metal device body in the walled-in box and fit it on the bottom using a Torx head screw.



**CAUTION**

Loosen the screw if too tight to make the device fit in the box. Then tighten the screw again.

## Electric Installation

### Power Supply

**2N IP One** can be fed either directly from the LAN if equipped with PoE 802.3af supporting network elements or from an external 12 V  $\pm$ 15 % / 2 A DC power supply.

**CAUTION**

The device must be part of the electrical system of the building.

**PoE Supply**

**2N IP One** is compatible with the PoE 802.3af technology (Class 0–12.95 W) and can be supplied directly from the LAN via compatible network elements. If your LAN does not support this technology, insert a PoE injector, Part No. **91378100**, between **2N IP One** and the nearest network element. This power supply provides **2N IP One** with 12 W for its own feeding and for connected modules.

**External Power Supply**

Use a SELV supply 12 V  $\pm$ 15 % dimensioned to the current consumption required for feeding the device to make your device work reliably.

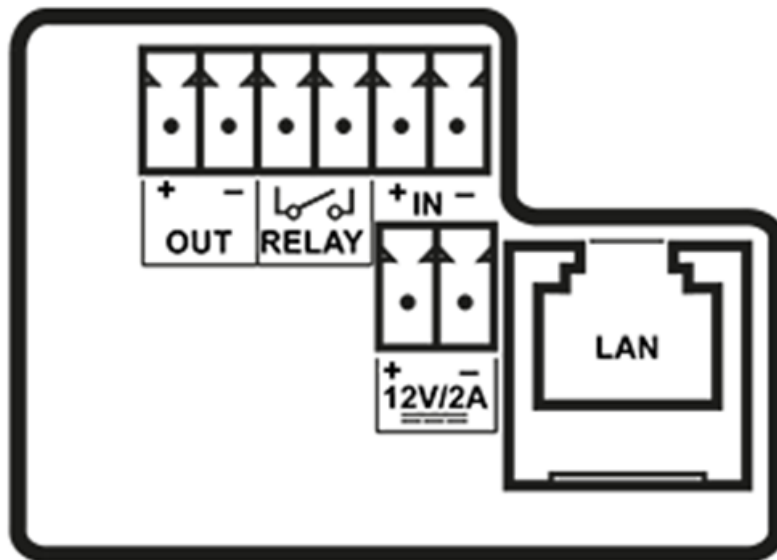
Current consumption [A]	Available power output [W]
2	24

**Combined Power Supply**

**2N IP One** can be fed from an external power supply and PoE at the same time. In this configuration, the maximum power for the is available.

## Device Connectors

Figure 1. Main unit connector wiring



OUT	Active switch output: 12 V DC, max. 600 mA
RELAY	RELAY terminals with accessible 30 V / 1 A AC/DC NO contact.
IN	IN1 terminals for input in passive/ active mode (-30 V to +30 V DC) <ul style="list-style-type: none"> <li>• OFF = open contact or <math>U_{IN} &gt; 1.5 \text{ V}</math></li> <li>• ON = closed contact or <math>U_{IN} &lt; 1.5 \text{ V}</math></li> </ul>
12 V / 2 A	External power supply terminals /
LAN	LAN connector (PoE 802.3af)

### LAN Connection

**2N IP One** is connected to the LAN by inserting a SSTP cable (category Cat-5e or higher) in the dedicated LAN connector on the device. As the device is equipped with the Auto-MDIX function, you can use either the straight or crossed cable version.



### WARNING

This device cannot be connected directly to telecom lines (or public wireless networks) of any telecom service providers (i.e. mobile providers, landline providers or Internet providers). A router has to be used for the device Internet connection.



### CAUTION

- We recommend the use of a LAN [surge protection \(p. 23\)](#).
- We recommend the use of a shielded SFTP Ethernet cable.

## Overvoltage Protection

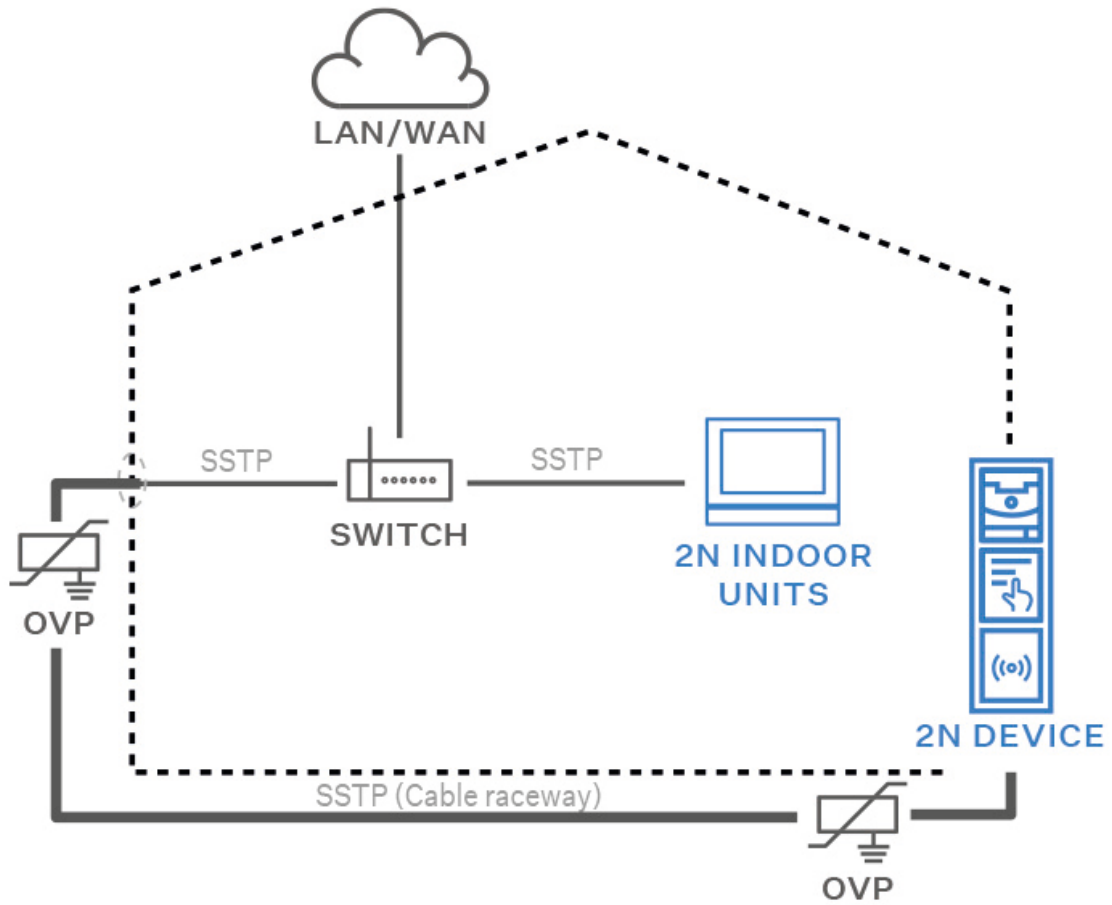
The 2N device cables have to be protected against atmospheric overvoltage caused by external causes (lightning, e.g.). A surge can damage a device installed outside/inside the building if the wires are unprotected.

Therefore, we recommend that additional overvoltage protectors (OVP) be installed on the outer walls or roof for all the wires leading outside the building. Keep the following instructions while installing overvoltage protectors:

- Make sure that the overvoltage protector is installed as close as possible to the device installed outside the building.
- Make sure that the overvoltage protector is installed as close as possible to the device installed on an external part of the building.
- Make sure that the overvoltage protector is installed as close as possible to the point where the cabling leaves the building.

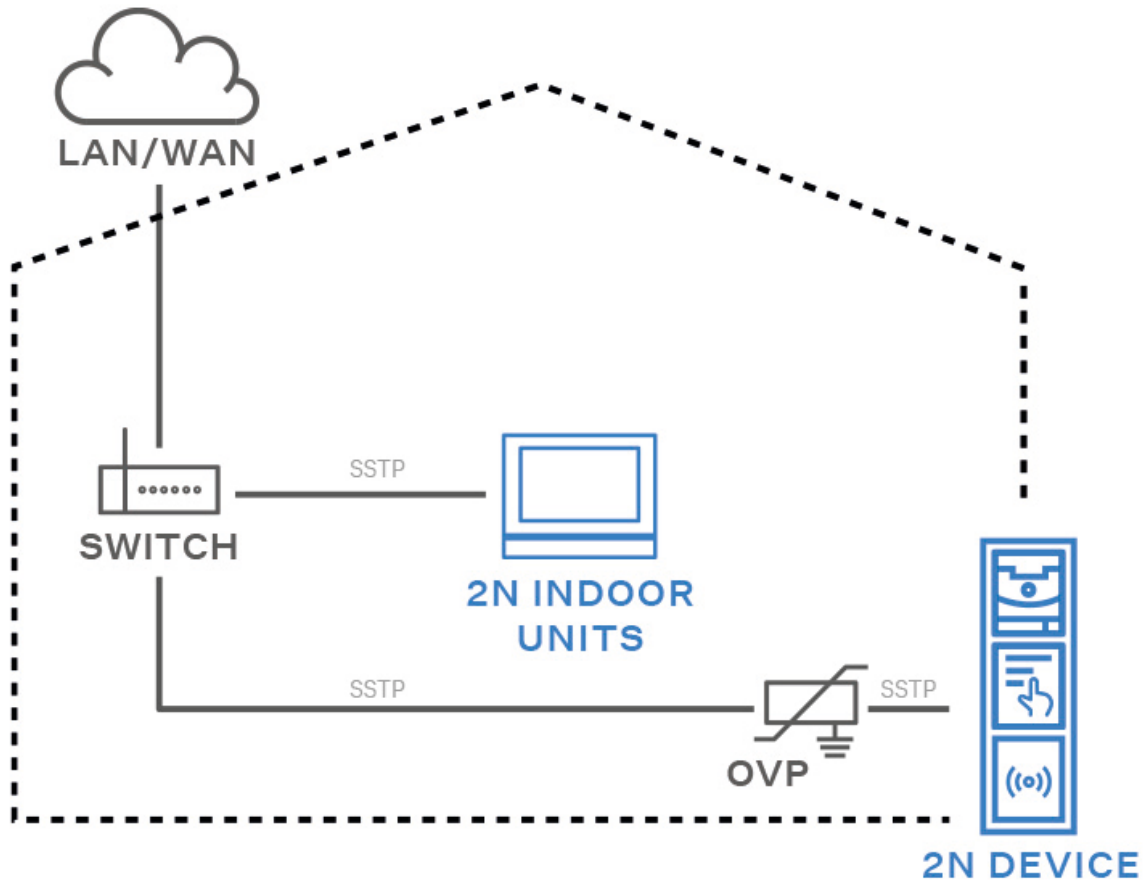
### Examples of Overvoltage Protection Installation

Figure 2. Overvoltage protection installation diagram for a device installed on the building facade and cables outside the building

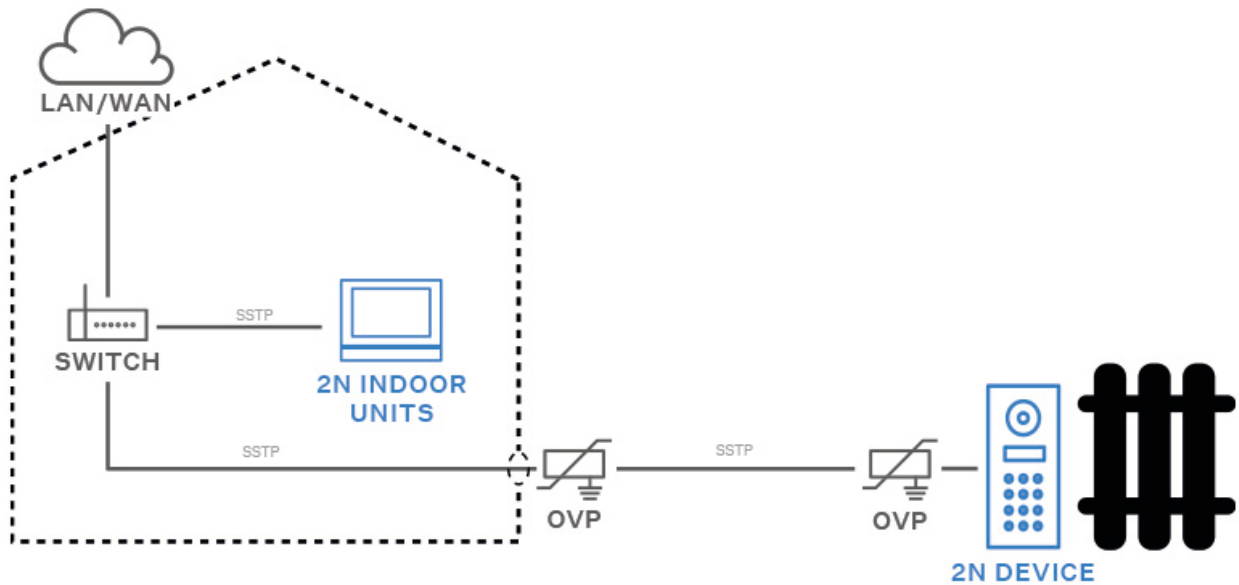




**Figure 3. Overvoltage protection installation diagram for a device installed on the building facade and cables inside the building**



**Figure 4. Overvoltage protection installation diagram for a device and cables installed outside the building**



## Main and Extending Modules

2N IP One can be interconnected with the following modules:

- [Security Relay \(p. 26\)](#)



### CAUTION

In case the firmware versions of the module to be connected and the main unit are incompatible, the module will not be detected. Therefore, update the device firmware after connecting the modules. Update firmware via the web configuration interface in System > Maintenance.

## Module Specifications

### Security Relay

The Security Relay (Part No. **9159010**) is used for enhancing security between **2N IP One** and the connected electric lock. The Security Relay significantly enhances security of the connected electric lock by preventing unlocking due to device tampering.

**TIP**

FAQ: 2N IP Security Relay – description of the device and use with the 2N intercoms

## Specification

Passive switch      NO/NC contact, up to 30 V / 1 A AC/DC

Switched output

- Where the Security Relay is fed from the device, 9 to 13 V DC is available on the output depending on the power supply (PoE: 9 V; adapter: source voltage of minus 1 V) / 400 mA DC.
- Where the Security Relay is fed from an external power supply, 12 V / 700 mA DC is available on the output.

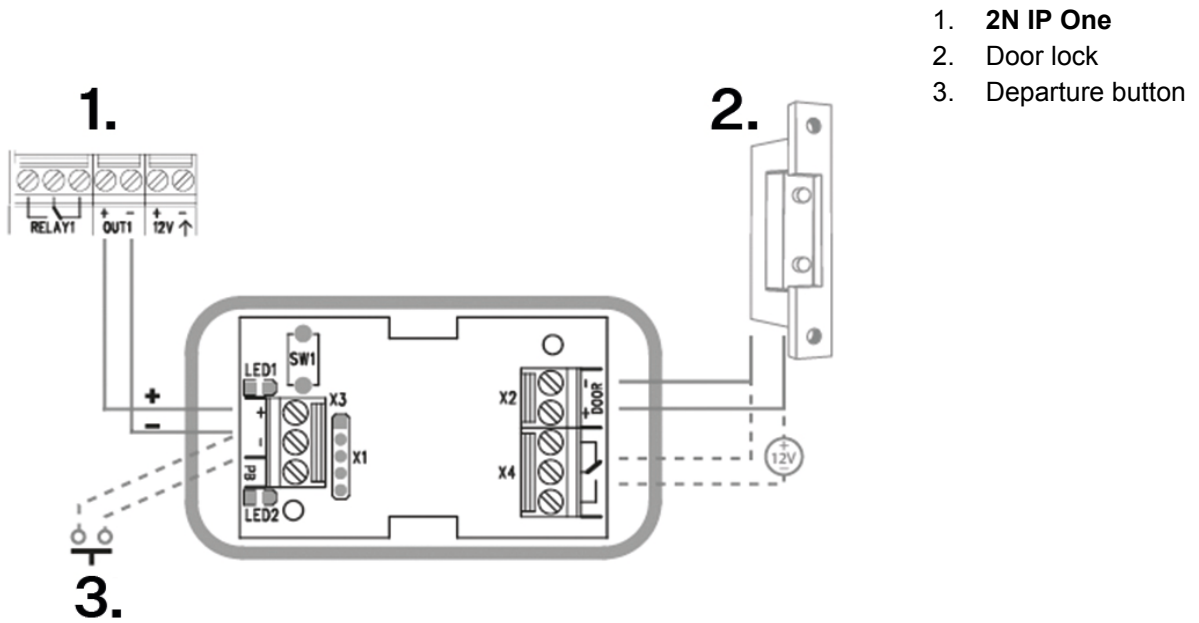
Dimensions (w x h x d)      56 x 31 x 24 mm

Weight      20 g

## Connectors and Installation

The Security Relay is installed between the device (outside the secured area) and the electric lock (inside the secured area). The Security Relay includes a relay that can only be activated if a valid access card/code is detected on the unit.

The Security Relay is installed on a two-wire cable between the device and the electric lock inside the area to be secured (typically behind the door). The Security Relay is powered and controlled via this two-wire cable and can thus be added to an existing installation. Thanks to its compact dimensions, the device can be installed into a standard mounting box.



Connect the Security Relay to the access unit as follows:

- To the Active output

Connect the electric lock to the Security Relay as follows:

- to the switched output
- to the passive output in series with the external power supply

The Security Relay also supports the Departure button connected to the 'PB' and '- HeliosIP/2N IP intercom' terminals. Once the Departure button is pressed, the output is activated for 5 seconds.



**TIP**

Video: [Security Relay Installation and Setting](#)

## Status Signaling

Green LED	Red LED	State
flashing	off	Operational mode
on	off	Activated output
flashing	flashing	Programming mode – waiting for initialization
on	flashing	Error – wrong code

## Configuration

1. Connect the Security Relay to the properly set Security output of the device. Refer to the Configuration Manual for details. Make sure that one LED at least is on or flashing.
2. Press and hold the Relay RESET button for 5 seconds to switch the device in the programming mode (red and green LEDs flashing).
3. Activate the output switch using the keypad, telephone, etc. The first code sent from the access unit will be stored in the memory and considered valid. After code initialization, the Security Relay will pass into the operational mode (green LED flashing).



### CAUTION

Having reset the factory defaults on a device with firmware 2.18 or higher, remember to reprogram Security Relay using the instructions above.

## Installation Completion

Check the connection of all the wires in the board connector.



### WARNING

- Make sure that all the terminals of the unused connectors are properly tightened to avoid vibrations caused by sound.
- An incorrectly made installation may compromise the device waterproofness. Water infiltration may damage the electronic part.
- Make sure that all the holes are filled with some waterproof material – the top part, around the cables and the screws.
- Use silicone or some other sealant to seal the box against an uneven wall. Thus, you prevent water leakage and wall damping.

# Brief Guidelines

- [Device Configuration Interface Access \(p. 30\)](#)
- [IP Address Retrieval \(p. 31\)](#)
- [Dynamic/Static IP Address Switching \(p. 32\)](#)
- [Firmware Update \(p. 33\)](#)
- [Device Restart \(p. 32\)](#)
- [Factory Default Reset](#)
- [Call Connection \(p. 33\)](#)

## Device Configuration Interface Access

**2N IP One** is configured via the administration web interface. Connect the device to the LAN IP and make sure it is properly powered. You have to know the IP address for access.

### Domain Name

Enter the domain name as "hostname.local". The new device Hostname consists of the device name and serial number. See below for the device name formats in Hostname. The serial number is entered without hyphens. You can change Hostname in System > Network later.

**Default domain name 2N IP One:** 2NIPOne-{serial number without dashes}.local (e.g.: "2NIPOne-0000000001.local")

Login based on a domain name is advantageous if the dynamic IP address is used. While the dynamic IP address changes, the domain name remains the same. It is possible to generate certificates signed by a trusted certification authority for the domain name.

### IP address

To retrieve the device IP address, take the following steps, see :

- Use the freely accessible 2N Network Scanner.
- Use the Speed Dial button.

## Web Configuration Interface Login

1. Fill in the **2N IP One** address or domain name into the internet browser.

The login screen is now displayed.

Should the login screen fail to appear, you must have typed a wrong IP address, port, domain name or the administration web server has been switched off. If you do not have a certificate generated for the IP address or domain name, an invalid security certificate warning may be displayed. In this case, you need to confirm that you want to go to the web configuration interface.

2. Enter the login data.

The default login data are:

Username: **Admin**

Password: **2n**

It is necessary to change the password immediately upon the first login.

**TIP**

It is recommended that a password is used that is difficult to break. It is not recommended that names, places or things, especially those closely related to the user, are used in the password.

For increased password security, it is recommended that:

- the random password generator is used,
- the password length is 12 characters at least,
- various characters from different character sets are combined (small/capital letters, digits, special characters, etc.).

## IP Address Retrieval

To retrieve the device IP address, take the following steps:

- Use the freely accessible 2N Network Scanner.
- Use the Speed Dial button.

### IP Address Retrieval Using 2N Network Scanner

The application helps you find the IP addresses of all the 2N devices in the LAN. Download 2N Network Scanner from the [2N.com](http://2N.com) website. Make sure that Microsoft .NET Framework 2.0 is installed for successful app installation.

1. Run the 2N Network Scanner installer.
2. The Installation Wizard will help you with the installation.
3. Having installed 2N Network Scanner, start the application using the Microsoft Windows Start menu. Once started, the application begins to automatically search the LAN for all the 2N devices which have been DHCP/statically assigned IP addresses. These devices are then shown in a table.

2N® Network Scanner (version 3.0.4)

File Help

Filter

IP Address	Serial Number	Display Name	Version
10.0.24.69	54-1921-5022	2N IP Verso Mobile Team	2.29.0.38.6
10.0.24.73	52-1953-0073	2N Indoor Touch 2.0	4.0.0
10.0.24.74	54-0956-0004	2N Indoor Touch	3.4.0.1.0
10.0.24.75	52-1953-0064	2N Indoor Touch 2.0	999.4.3.0 (eng.378...
10.0.24.78	52-1953-0079	2N Indoor Touch 2.0	999.4.4.0 (eng.502...
10.0.24.79	52-2339-0077	2N Indoor Compact	2.30.0.39.0
10.0.24.87	52-2101-0046	2N Indoor Touch 2.0	4.3.0 (rc.4.3.x)
10.0.24.102	52-1953-0098	2N Indoor Touch 2.0	999.4.4.0 (eng.496...
10.0.24.105	52-2656-0067	2N Indoor View	2.29.0.38.6
10.0.24.108	52-2700-0559	2N Indoor Touch 2.0	999.4.4.0 (eng.494...
10.0.24.116	52-2667-0295	2N Indoor Touch 2.0	4.2.2 (release.4.2.2)
10.0.24.123	99-8888-0035	2N Indoor Touch 2.0	999.4.1.7 (eng.root...

Count: 15

4. Select the device to be configured and right-click it. Select *Browse...* to open the device administration web interface login box for configuration.



**TIP**

- Double click the selected row in the 2N Network Scanner list to access the device web interface easily.
- To change the device IP address, select *Config* and enter the required static IP address or activate DHCP.

The default login data are:

Username: **Admin**

Password: **2n**

It is necessary to change the password immediately upon the first login.



**CAUTION**

If the found device is grey highlighted, its IP address cannot be configured using this application. In that case, click Refresh to find the device again and check whether multicast is enabled in your network.



**TIP**

It is recommended that a password is used that is difficult to break. It is not recommended that names, places or things, especially those closely related to the user, are used in the password.

For increased password security, it is recommended that:

- the random password generator is used,
- the password length is 12 characters at least,
- various characters from different character sets are combined (small/capital letters, digits, special characters, etc.).

## Dynamic/Static IP Address Switching

Press the Speed dial button 15 times to switch the static IP address (DHCP OFF) / dynamic IP address (DHCP OFF) mode in the device network configuration.

## Device Restart

To restart the device choose one of the following options:

- using disconnection from the power supply,
- via the web configuration interface.



**NOTE**

The device restart does not result in any change in the configuration settings.



## Restart Using Web Configuration Interface,

You can restart the device via the web configuration interface. Refer to [Web Configuration Interface Login \(p. 30\)](#) for login details. Restart the device in System > [Maintenance](#) > System using **Restart**.

## Firmware Update

We recommend that the firmware is also updated during the **2N IP One** installation. Refer to [2N.com](#) for the latest FW version.

Update firmware via the web configuration interface in System > Maintenance, refer to the device Configuration Manual.

Once the firmware is uploaded successfully, the device is restarted automatically.



### TIP

You can make bulk updates for multiple devices via 2N Access Commander.

## Factory Default Reset

Located among the main unit connectors, the [CONTROL](#) button helps you reset the factory default values.

1. Disconnect the device from the power supply.
2. Press and hold the CONTROL button.
3. Connect the device to the power supply.
4. Keep holding the button for a few seconds and then release it.



### CAUTION

In case the factory default values are reset on the device with a firmware version 2.18 or higher, it is necessary to reprogram the 2N Security Relay using the instructions given in [Security Relay \(p. 26\)](#).


## Call Connection

To make calls with other terminal devices in IP networks, it is necessary to assign the device to a contact in the Directory.

### Connection with 2N Devices in LAN

1. Make sure that [Local Calls](#) is enabled on both the 2N devices.
2. Click **Find device** above the table. Check the listed device that you want to establish connection to. Once the device is added, editing becomes available.
3. Edit the following:
  - a virtual number to start a call by entering the number via your numerical keypad
  - basic information and access options for the device user.
4. To dial calls with a device button, assign the selected user to the quick dial button in Hardware > Buttons, refer to Buttons.
5. Make sure that [Local Calls](#) is enabled on the called 2N device to make a successful call.

## Connection with Other Devices

1. Click **Add user** or open the existing contact detail to create a new contact.
2. Click the pencil icon next to the Phone number  to open phone number editing.
3. Select the type of call:
  - “SIP” for calls via SIP
  - “rava” for calls with Creston
  - “vms” for calls with Axis Camera Station
  - “device” for calls with a local 2N device
4. Enter the calling destination address into the destination field to which the call is to be routed. Complete the target IP address or SIP URI in the format “ user\_name@host” (e.g.: “johana@2.255.4.255” or “johana@calls.2N.com”). For local calls, fill in the called 2N device ID as specified in the [Local Calls](#) tab in the called device web interface.
5. Edit the following:
  - a virtual number to start a call by entering the number via your numerical keypad
  - basic information and access options for the device user.
6. To dial calls with a device button, assign the selected user to the quick dial button in Hardware > Buttons, refer to Buttons.
7. Make sure that the call transmitting service is enabled on the called 2N device to make a successful call.



### TIP

- Each user can be assigned up to 3 phone numbers. In case the first user fails to answer, the call is forwarded to the next number. Alternatively, you can set calling to multiple phone numbers simultaneously. Check Call in group between the selected numbers to set such multiple phone number calling for one user.
- In case all the user phone numbers are unavailable, you can set call forwarding to Deputy.
- Users can be gathered in calling groups. The calling group name is shown in the phone book on the device display. You can assign a calling group to a quick dial button. To terminate an outgoing group call after the first rejection from any of the called users, set this function in Calls > [Calls](#).

## Device Control

**2N IP One** is an intercom allowing you to:

- call other devices using a speed dial button
- receive and reject incoming calls
- activate the switch (door unlocking, lift control, etc.) by entering a numerical access code via the **2N Mobile Key** keypad
- control the device using a touch display
- activate/deactivate users or profiles using the 2N Mobile Key mobile application

# Troubleshooting



Refer to [faq.2n.cz](http://faq.2n.cz) for the most frequently solved problems.

## Technical Parameters

### Power Supply Types

PoE IEEE 802.3af, Class 0 (0.44–12,95 W, 44-57 V DC, 400 mA)

External supply 12 V  $\pm$ 15 % / 2 A DC

### Signaling protocol

SIP UDP, TCP, TLS

### Audio

Microphone Electret

Amplifier 3 W RMS / 6 W (class D)

Speaker 3 W / 4  $\Omega$

Sound pressure level (SPL max) 78 dB (for 1 kHz, distance 1 m)

Volume Control Adjustable with automatic adaptive mode

Full duplex Yes (AEC)

Audio power output 1.9 W

## Technical Parameters

### Audio stream

Protocols	<ul style="list-style-type: none"><li>• RTP</li><li>• RTSP</li></ul>
Codecs and Used Bandwidth	<ul style="list-style-type: none"><li>• G.711 (PCMA, PCMU) – 64 kbps (with 85.6 kbps headers)</li><li>• G.729 – 16 kbps (with 29.6 kbps headers)</li><li>• G.722 – 64 (with 85.6 kbps headers)</li><li>• L16/16kHz – 256 kbps (with 277.6 kbps headers)</li></ul>

### Camera

Sensor	1/2.7" colour CMOS
JPEG resolution	Up to 1920 x 1440 (4:3); FHD (16:9)
Video resolution	1920 x 1440 (4:3); FHD (16:9)
Frame rate	up to 30 frames
Sensor sensitivity	14000e-/lux-sec
Viewing angle	138° (H), 114° (V)
Infrared illumination	Yes
Focal length	1.935 mm

## Technical Parameters

### Video stream

Protocols	<ul style="list-style-type: none"><li>• RTP</li><li>• RTSP</li><li>• SRTP</li><li>• HTTP</li></ul>
ONVIF/RTSP streaming codecs	<ul style="list-style-type: none"><li>• H.264, MJPEG</li><li>• H.265</li><li>• MJPEG</li></ul>
IP Camera Function	Yes – compatible profiles: <ul style="list-style-type: none"><li>• ONVIF v2.4 profile S</li></ul>

### Interface

LAN	10/100BASE-TX s Auto-MDIX, RJ-45
Recommended cabling	Cat-5e or higher
Switched voltage	Max. 20 V AC or 30 V DC
Passive switch (relay)	30 V / 1 A AC/DC NO contact

## Technical Parameters

### Mechanical Parameters

Cover	Hardened glass
Body material	<ul style="list-style-type: none"><li>• Black version:<ul style="list-style-type: none"><li>• Material - Zamak 410 - Zn95Al4Cu1</li><li>• Surface treatment – PUR Wet coating 15-25 µm, RAL 9005 Jet black, inner side - passivated zinc</li></ul></li></ul>
Body material	<ul style="list-style-type: none"><li>• Material – EN AC-46100</li><li>• Surfacing – RAL 7021 (black version) / RAL 9023 (gray version) / Steel Bronze (bronze version)</li></ul>
Dimensions (w x h x d)	78 x 172 x 10 mm
Weight	355 g
Operating temperature	-30 °C to 60 °C
Relative humidity	10 to 95 % (non-condensing)
Storing temperature	-30 °C to 70 °C
Protection class	IP66
Resistance level	IK08



# Directives, Laws and Regulations - General Instructions and Cautions

**2N IP One** conforms to the following directives and regulations:

- 2014/30/EU for electromagnetic compatibility
- 2014/53/EU for radio equipment
- 2011/65/EU on the restriction of the use of certain hazardous substances in electrical and electronic equipment
- 2012/19/EU on waste electrical and electronic equipment

## Industry Canada

This Class B digital apparatus complies with Canadian ICES-003/NMB-003.

## FCC

This equipment has been tested and found to comply with the limits for a Class B digital device, pursuant to part 15 of the FCC Rules.

NOTE: These limits are designed to provide reasonable protection against harmful interference in a residential installation. This equipment generates, uses and can radiate radio frequency energy and, if not installed and used in accordance with the instructions, may cause harmful interference to radio communications.

However, there is no guarantee that interference will not occur in a particular installation. If this equipment does cause harmful interference to radio or television reception, which can be determined by turning the equipment off and on, the user is encouraged to try to correct the interference by one or more of the following measures:

- Reorient or relocate the receiving antenna.
- Increase the separation between the equipment and receiver.
- Connect the equipment into an outlet on a circuit other than that to which the receiver is connected.
- Consult the dealer or an experienced radio/TV technician for help.

Changes or modifications to this unit not expressly approved by the party responsible for compliance could void the user's authority to operate this equipment.



**WARNING**

In order to ensure the full functionality and guaranteed performance, we strongly recommend that the topicality of the product / device version in use be verified as early as in the installation process. The customer hereby acknowledges that the product / device can achieve the guaranteed performance and full functionality pursuant to the manufacturer's instructions only if the latest product / device version is used after having been tested for full interoperability and not having been determined by the manufacturer as incompatible with certain versions of other products, and only in conformity with the manufacturer's instructions, guidelines or recommendations and in conjunction with suitable products and devices of other suppliers. The latest versions are available at [https://www.2n.com/cs\\_CZ/](https://www.2n.com/cs_CZ/) or can be updated via the configuration interface if the devices are adequately technically equipped. Should the customer use a product / device version other than the latest one or a version determined by the manufacturer as incompatible with certain versions of other products, or should the customer use the product / device in contradiction to the manufacturer's instructions, guidelines or recommendations or in conjunction with unsuitable products / devices of other suppliers, the customer is aware of and agrees with all functionality limitations of such a product / device if any as well as with all consequences incurred as a result thereof. Using a product / device version other than the latest one or a version determined by the manufacturer as incompatible with certain versions of other products, or using the product / device in contradiction to the manufacturer's instructions, guidelines or recommendations or in conjunction with unsuitable products / devices of other suppliers, the customer agrees that the 2N TELEKOMUNIKACE a.s. company shall not be held liable for any functionality limitation of such a product or any damage, loss or injury related to this potential functionality limitation.

Please read this User Manual carefully before using the product and follow the instructions and recommendations included therein.

Any use of the product that is in contradiction with the instructions provided herein may result in malfunction, damage or destruction of the product.

The manufacturer shall not be liable and responsible for any damage incurred as a result of a use of the product other than that included herein, namely undue application and disobedience of the recommendations and warnings.

Any use or connection of the product other than those included herein shall be considered undue and the manufacturer shall not be liable for any consequences arisen as a result of such misconduct.

Moreover, the manufacturer shall not be liable for any damage or destruction of the product incurred as a result of misplacement, incompetent installation and/or undue operation and use of the product in contradiction herewith.

The manufacturer assumes no responsibility for any malfunction, damage or destruction of the product caused by incompetent replacement of parts or due to the use of reproduction parts or components.

The manufacturer shall not be liable and responsible for any loss or damage incurred as a result of a natural disaster or any other unfavorable natural condition.

The manufacturer shall not be held liable for any damage of the product arising during the shipping thereof.

The manufacturer shall not make any warrant with regard to data loss or damage.

The manufacturer shall not be liable and responsible for any direct or indirect damage incurred as a result of a use of the product in contradiction herewith or a failure of the product due to a use in contradiction herewith.

All applicable legal regulations concerning the product installation and use as well as provisions of technical standards on electric installations have to be obeyed. The manufacturer shall not be liable and responsible for damage or destruction of the product or damage incurred by the consumer in case the product is used and handled contrary to the said regulations and provisions.

The consumer shall, at its own expense, procure software protection of the product. The manufacturer shall not be held liable for any damage incurred as a result of the use of deficient security software.

The consumer shall, without delay, change the access password for the product after installation. The manufacturer shall not be held liable or responsible for any damage incurred in connection with the use of the original password.

The manufacturer also assumes no responsibility for additional costs incurred by the consumer as a result of making calls to increased tariff lines.

## Electric Waste and Used Battery Pack Handling





Do not place used electric devices and battery packs into municipal waste containers. An undue disposal thereof might impair the environment!

Deliver your expired household electric appliances and battery packs removed from them to dedicated dumpsites or containers or give them back to the dealer or manufacturer for environmental-friendly disposal. The dealer or manufacturer shall take the product back free of charge and without requiring another purchase. Make sure that the devices to be disposed of are complete.

Do not throw battery packs into fire. Battery packs may not be taken into parts or short-circuited either.

## Legislation of Thailand

<p>เครื่องโทรคมนาคมและอุปกรณ์นี้มีความสอดคล้องตามมาตรฐานหรือข้อกำหนดทางเทคนิคของ กสทช.</p>
<p> nab.</p> <p>เครื่องวิทยุคมนาคมนี้ได้รับยกเว้นไม่ต้องได้รับใบอนุญาตให้มีใช้ซึ่งเครื่องวิทยุคมนาคมหรือตั้งสถานีวิทยุคมนาคมตามประกาศ กสทช. เรื่อง เครื่องวิทยุคมนาคม และสถานีวิทยุคมนาคมที่ได้รับยกเว้นไม่ต้องได้รับใบอนุญาตวิทยุคมนาคมตามพระราชบัญญัติวิทยุคมนาคม พ.ศ. 2498</p>
<p> <b>nab.</b>   โทรคมนาคม กำกับดูแลเพื่อประชาชน Call Center 1200 (InSW)</p>

# 2N



[wiki.2n.com](https://wiki.2n.com)

2N IP One – User Manual

© 2N Telekomunikace a. s., 2024

[2N.com](https://2n.com)