

2N Access Unit M Installation Manual



Content

- 1. Product Overview
 - 1.1 Components and Associated Products
 - 1.2 Terms and Symbols
- 2. Description of Installation
 - 2.1 Before You Start
 - 2.2 Mechanical Installation
 - 2.3 Electric Installation
 - 2.4 Extending Module Connection
- 3. Detection of 2N Access Unit M using 2N® Network Scanner
- 4. Factory Reset
- 5. Maintenance
- 6. Status Signaling
- 7. Technical Parameters
 - 7.1 General Drawings
- 8. Supplementary Information
 - 8.1 General Instructions and Cautions
 - 8.2 Troubleshooting
 - 8.3 Other Countries' Legislation
 - 8.4 Directives, Laws and Regulations

1. Product Overview

Here is what you can find in this section:

- [1.1 Components and Associated Products](#)
- [1.2 Terms and Symbols](#)

Basic Features

2N Access Unit M is an elegant and reliable access IP system equipped with a number of useful functions.

2N Access Unit M is a single-module access system available in several versions.

All the 2N Access Unit M versions include an integrated card reader module, which helps control access using an RFID card. With additional software settings, you can use the card to control more functions than just door lock switching too.

The 2N Access Unit M keypad version helps you control the electric lock switch by entering a valid numeric code via the numeric keypad. With additional software settings, you can use the numeric code to control more functions than just door lock switching too.

The 2N Access Unit M Bluetooth version helps you control the lock switch using the **2N[®] Mobile Key** application installed in your smartphone.

2N Access Unit M is designed as a robust, mechanically resistant IP55-rated access system, which withstands any weather conditions without requiring additional accessories.

The installation of **2N Access Unit M** is very easy. All you have to do is connect the system to your LAN via a mains cable. Feed the access system either from a 12V power supply or your PoE supporting LAN.

To configure 2N Access Unit M use a PC equipped with any Internet browser. Use **2N[®] Access Commander** to bulk manage extensive access system installations easily.

Advantages of Use

- Elegant mullion design
- Weather resistance (IP 55)
- Easy wall (surface) mounting (brick/pasterboard walls, door frames)
- Integrated electric lock switches with wide setting options
- Integrated RFID card reader module
- Bluetooth module version
- Backlit touch keypad version
- LAN (PoE) or external 12V power supply
- Configuration using web interface
- HTTP server for API configuration
- SNTP client for time synchronization
- SMTP client for email sending, Picture to Email feature

- TFTP/HTTP client for automated firmware and configuration upgrade and update

1.1 Components and Associated Products

Main Units	
<p>2N Part No. 916112</p> <p>Axis Part No. 02393-001</p> 	<ul style="list-style-type: none">• 2N[®] Access Unit M 13.56 MHz, NFC ready• is used for reading RFID cards in the 13.56 MHz bandwidth with the NFC support. Combining an access reader and a controller, the device is used for access control inside and outside of buildings.• The following RFID cards can be read:<ul style="list-style-type: none">• ISO14443A (Mifare, DESFire)• PicoPass (HID iClass)• Felica• ST SR(IX)• 2N[®] Mobile Key

Main Units

**2N Part No.
916114**

**Axis Part No.
02394-001**



- **2N[®] Access Unit M RFID 125 kHz, 13.56 MHz, NFC**
- is used for reading RFID cards in the 125 kHz and 13.56 MHz bandwidths with the NFC support. Combining an access reader and a controller, the device is used for access control inside and outside of buildings.
- **The following RFID cards can be read:**
 - EM4xxx
 - ISO14443A (Mifare, DESFire)
 - PicoPass (HID iClass)
 - Felica
 - ST SR(IX)
 - 2N[®] Mobile Key

Main Units

**2N Part No.
916115**

**Axis Part No.
02395-001**



- **2N[®] Access Unit M Bluetooth & RFID 125 kHz, 13.56 MHz, NFC**
- is used for reading RFID cards in the 125 kHz and 13.56 MHz bandwidths with the NFC support. Combining an access reader, a Bluetooth module and a controller, the device is used for access control inside and outside of buildings.
- **The following RFID cards can be read:**
 - EM4xxx
 - ISO14443A (Mifare, DESFire)
 - PicoPass (HID iClass)
 - Felica
 - ST SR(IX)
 - 2N[®] Mobile Key

Main Units	
<p>2N Part No. 916116</p> <p>Axis Part No. 02396-001</p> 	<ul style="list-style-type: none"> • 2N[®] Access Unit M Touch Keypad & RFID 125 kHz, 13.56 MHz, NFC • is used for reading RFID cards in the 125 kHz and 13.56 MHz bandwidths with the NFC support. Combining an access reader, a touch keypad and a controller, the device is used for access control inside and outside of buildings. • The following RFID cards can be read: <ul style="list-style-type: none"> • EM4xxx • ISO14443A (Mifare, DESFire) • PicoPass (HID iClass) • Felica • ST SR(IX) • 2N[®] Mobile Key
License	
<p>2N Part No. 916012</p> <p>Axis Part No. 01369-001</p>	<ul style="list-style-type: none"> • 2N Access Unit NFC license
<p>2N Part No. 9160401</p> <p>Axis Part No. 02000-001</p>	<ul style="list-style-type: none"> • 2N Access Unit Lift module license



Electric Locks



<p>Part No. 11202101</p> 	<ul style="list-style-type: none"> • Mini electronic doorstrike series 5 • electric opener designed for door frame installation • intended for such narrow profiles as aluminum, wood or PVC in particular • short sheet metal front cover version (130 mm) • 16 mm width
<p>Part No. 11202101-L</p> 	<ul style="list-style-type: none"> • Mini electronic doorstrike series 5 - long • electric opener designed for door frame installation • intended for such narrow profiles as aluminum, wood or PVC in particular • long sheet metal front cover version (250 mm) • 16 mm width
<p>Part No. 11202102</p> 	<ul style="list-style-type: none"> • Mini electronic doorstrike series 5 - with momentum pin • electric opener designed for door frame installation • intended for such narrow profiles as aluminum, wood or PVC in particular • short sheet metal front cover version (130 mm) • 16 mm width

<p>Part No. 11202102-L</p> 	<ul style="list-style-type: none"> • Mini electronic doorstrike series 5 – with momentum pin, long • electric opener designed for door frame installation • intended for such narrow profiles as aluminum, wood or PVC in particular • long sheet metal front cover version (250 mm) • 16 mm width
<p>Part No. 11202103</p> 	<ul style="list-style-type: none"> • Mini electronic doorstrike series 5 – with mechanical blocking • electric opener designed for door frame installation • intended for such narrow profiles as aluminum, wood or PVC in particular • short sheet metal front cover version (130 mm) • 16 mm width
<p>Part No. 11202103-L</p> 	<ul style="list-style-type: none"> • Mini electronic doorstrike series 5 – with mechanical blocking, long • electric opener designed for door frame installation • intended for such narrow profiles as aluminum, wood or PVC in particular • long sheet metal front cover version (250 mm) • 16 mm width

<p>Part No. 11202104</p> 	<ul style="list-style-type: none"> • Mini electronic doorstrike series 5 – door signaling • electric opener designed for door frame installation • intended for such narrow profiles as aluminum, wood or PVC in particular • including a door state monitoring micro switch: open/closed • short sheet metal front cover version (130 mm) • 16 mm width
<p>Part No. 11202104-L</p> 	<ul style="list-style-type: none"> • Mini electronic doorstrike series 5 – door signaling, long • electric opener designed for door frame installation • intended for such narrow profiles as aluminum, wood or PVC in particular • including a door state monitoring micro switch: open/closed • long sheet metal front cover version (250 mm) • 16 mm width
<p>Part No. 11202105</p> 	<ul style="list-style-type: none"> • Mini electronic doorstrike series 5 – fail-safe • electric opener designed for door frame installation • intended for such narrow profiles as aluminum, wood or PVC in particular • under voltage: opener secured, blocked • at voltage interruption: opener unblocked, door can be opened • short sheet metal front cover version (130 mm) • 16 mm width

<p>Part No. 11202105-L</p> 	<ul style="list-style-type: none"> • Mini electronic doorstrike series 5 – fail-safe, long • electric opener designed for door frame installation • intended for such narrow profiles as aluminum, wood or PVC in particular • under voltage: opener secured, blocked • at voltage interruption: opener unblocked, door can be opened • long sheet metal front cover version (250 mm) • 16 mm width
<p>Part No. 11202106</p> 	<ul style="list-style-type: none"> • Mini electronic doorstrike series 5 – fail-safe and door signaling • electric opener designed for door frame installation • intended for such narrow profiles as aluminum, wood or PVC in particular • under voltage: opener secured, blocked • at voltage interruption: opener unblocked, door can be opened • short sheet metal front cover version (130 mm) • 16 mm width
<p>Part No. 11202106-L</p> 	<ul style="list-style-type: none"> • Mini electronic doorstrike series 5 – fail-safe and door signaling, long • electric opener designed for door frame installation • intended for such narrow profiles as aluminum, wood or PVC in particular • under voltage: opener secured, blocked • at voltage interruption: opener unblocked, door can be opened • long sheet metal front cover version (250 mm) • 16 mm width

<p>Part No. 11202201</p> 	<ul style="list-style-type: none"> • Electromechanical lock SAM 7255 • 72/55 self-locking lock with panic function • A key is necessary for door opening from the outside (or an electric pulse from a connected 2N IP intercom / reader). • convenient solution for emergency exits
<p>Part No. 11202201-M</p> 	<ul style="list-style-type: none"> • Electromechanical lock SAM 7255 with monitoring • 72/55 self-locking lock with panic function • A key is necessary for door opening from the outside (or an electric pulse from a connected 2N IP intercom / reader). • convenient solution for emergency exits
<p>Part No. 11202202</p> 	<ul style="list-style-type: none"> • Electromechanical lock SAM 9235 • 92/35 self-locking lock with panic function • A key is necessary for door opening from the outside (or an electric pulse from a connected 2N IP intercom / reader). • convenient solution for emergency exits

<p>Part No. 11202202-M</p> 	<ul style="list-style-type: none"> • Electromechanical lock SAM 9235 with monitoring • 92/35 self-locking lock with panic function • A key is necessary for door opening from the outside (or an electric pulse from a connected 2N IP intercom / reader). • convenient solution for emergency exits
<p>Part No. 11202301</p> 	<ul style="list-style-type: none"> • Cable protector FX290 • Provides secure passage and protection of the supply cable between the door frame and the door leaf. • 290 mm length
<p>Part No. 11202302</p> 	<ul style="list-style-type: none"> • Cable protector FX510 • Provides secure passage and protection of the supply cable between the door frame and the door leaf. • 510 mm length

Part No. 11202303



- **Cable protector FX300G**
- Provides secure passage and protection of the supply cable between the door frame and the door leaf.
- 440 mm length

Part No. 11202304



- **Cable protector FX500G**
- Provides secure passage and protection of the supply cable between the door frame and the door leaf.
- 640 mm length

Part No. 11202107



- **Maglock MEX100**
- used as a door holding supplement, not replacing the lock
- consists of two parts: supplied part and counterpart
- under voltage: door cannot be opened
- at voltage interruption: magnets get disconnected, door opens

Part No. 11202501



- **Magnetic handle P300RP**
- fully replaces a mortise lock and handle
- under voltage: door cannot be opened
- at voltage interruption: magnets get disconnected, door opens
- suitable for wooden, metal and glass doors

Part No. 11202401



- **ED100**
- low energy simple door operator
- contactless operation
- can be interconnected with a motion sensor and electronic access control system
- applicable for right / left doors
- in / out opening versions

✓ **Tip**

- FAQ: [Electric locks – Differences between locks for 2N IP access systems](#)

Power Supply

Part Numbers

91378100E

91378100US



- PoE injector – without cable
- PoE injector – with EU cable
- PoE injector – with US cable
- For intercom supply via Ethernet cable where the PoE switch is absent.

Part Nos.

91341482E

91341482US





- 12 V / 1 A adapter
- A stabilized power supply needs to be used where no PoE is available.



**Part
No. 932928**







- 12 V transformer
- for electric lock

Additional Modules	
<p>2N Part No. 9159010</p> <p>Axis Part No. 01386-001</p> 	<ul style="list-style-type: none"> • Security Relay • A handy add-on that significantly enhances door entry security Prevents lock tampering. Installed between the intercom, from which it is also supplied, and the lock to be controlled.
<p>Part No. 9159013</p> 	<ul style="list-style-type: none"> • Departure button • Connects the logic input for door unlocking from inside the building.
<p>2N Part No. 9159012</p> <p>Axis Part No. 01388-001</p> 	<ul style="list-style-type: none"> • Magnetic door contact • Set for installation on a door, enabling the status of door opening to be ascertained. Used when the intercom is used for door protection, to detect when the door is not closed or forced open.

Additional Modules	
<p>2N Part No. 9134173</p> <p>Axis Part No. 01384-001</p> 	<ul style="list-style-type: none"> • RFID card, Mifare Classic 1k, 13.56 MHz
<p>2N Part No. 9134174</p> <p>Axis Part No. 01385-001</p> 	<ul style="list-style-type: none"> • RFID fob, Mifare Classic 1k, 13.56 MHz
<p>2N Part No. 9134165E</p> <p>Axis Part No. 01395-001</p> 	<ul style="list-style-type: none"> • RFID card, type EM4100, 125 kHz

Additional Modules	
<p>2N Part No. 9134166E Axis Part No. 01396-001</p> 	<ul style="list-style-type: none"> • RFID fob, type EM4100, 125 kHz
<p>2N Part No. 9137420E Axis Part No. 01399-001</p> 	<ul style="list-style-type: none"> • External RFID card reader connectable to a PC via a USB interface. • Suitable for system administration and adding of EM41xx cards (125 kHz) via a web interface or 2N® Access Commander.
<p>2N Part No. 9137421E Axis Part No. 01400-001</p> 	<ul style="list-style-type: none"> • USB Reader of 13.56 MHz, 125 kHz RFID Cards and NFC/HCE devices • External RFID card reader connectable to a PC via a USB interface. Suitable for system administration and adding 13.56 MHz, 125 kHz cards and Android platform devices supporting NFC/HCE using 2N IP intercom web interface or 2N® Access Commander. It reads the same types of cards and devices as card readers in 2N IP intercoms. <ul style="list-style-type: none"> • <u>13.56 MHz/ISO/IEC 14443A</u> Mifare Classic 1k & 4k, DESFire EV1, Mini, Plus S&X, Ultralight, Ultralight C • <u>13.56 MHz/ISO/IEC 14443B</u> CEPAS, HID iCLASS (CSN only) • <u>13.56/JIS X 6319</u> Felica • <u>ISO/IEC 18092</u> SmartPhone with NFC/HCE support, Android version 6.0 Marshmallow and higher (2N® Mobile Key required) • EMarine

Additional Modules	
<p>2N Part No. 9137424E</p> <p>Axis Part No. 01527-001</p> 	<ul style="list-style-type: none"> • Secured USB Reader of 13.56 MHz, 125 kHz RFID Cards and NFC/HCE devices • External secured RFID card reader connectable to a PC via a USB interface. Suitable for system administration and adding 13.56 MHz, 125 kHz cards and Android platform devices supporting NFC/HCE using the 2N IP intercom web interface or 2N® Access Commander. It reads the same types of cards and devices as card readers in 2N IP intercoms. <ul style="list-style-type: none"> • <u>13.56 MHz/ISO/IEC 14443A</u> Mifare Classic 1k & 4k, DESFire EV1, Mini, Plus S&X, Ultralight, Ultralight C • <u>13.56 MHz/ISO/IEC 14443B</u> CEPAS, HID iCLASS (CSN or PAC ID) • <u>13.56MHz/JIS X 6319</u> Felica • <u>ISO/IEC 18092</u> SmartPhone with NFC/HCE support, Android version 6.0 Marshmallow and higher (2N® Mobile Key required) • EMarine
<p>2N Part No. 9137410E</p> <p>Axis Part No. 01397-001</p> 	<ul style="list-style-type: none"> • External IP relay – 1 output • A stand-alone IP device, which can be controlled from an IP intercom via HTTP commands, which can thus control devices on unlimited distance.

Additional Modules	
<p>2N Part No. 9137411E</p> <p>Axis Part No. 01398-001</p> 	<ul style="list-style-type: none"> • External IP relay – 4 outputs, PoE • A stand-alone IP device, which can be controlled from an IP intercom via HTTP commands, which can thus control devices on unlimited distance.
<p>Part No. 9159014EU/US/UK</p> 	<ul style="list-style-type: none"> • 2N[®] 2Wire • (set of 2 adapters plus EU/US/UK power supply) • The 2N[®] 2Wire converter allows you to use the existing 2-wire cabling from your original door bell or door intercom to connect any IP device. You do not have to configure anything, all you need is one 2N[®] 2Wire unit at each end of the cable and a power supply connected to at least one of these units. 2N[®] 2Wire then provides PoE power not only to the second converter, but also to all the other IP end devices connected.
<p>2N Part No. 9160501</p> <p>Axis Part No. 0820-001</p> 	<ul style="list-style-type: none"> • AXIS A9188 Network I/O relay module • Lift control relay module for up to 8 floors

License

2N Part No. 9137909	<ul style="list-style-type: none"> • Gold
2N Part No. 9137910 Axis Part No. 01381-001	<ul style="list-style-type: none"> • InformaCast

 **Tip**

- Refer to the local 2N distributor for more accessories and recommendations please.

1.2 Terms and Symbols

The following symbols and pictograms are used in the manual:

 **Safety**

- **Always abide** by this information to prevent persons from injury.

 **Warning**

- **Always abide** by this information to prevent damage to the device.

 **Caution**

- **Important information** for system functionality.

 **Tip**

- **Useful information** for quick and efficient functionality.

 **Note**

- Routines or advice for efficient use of the device.

2. Description of Installation

Here is what you can find in this section:

- [2.1 Before You Start](#)
- [2.2 Mechanical Installation](#)
- [2.3 Electric Installation](#)
- [2.4 Extending Module Connection](#)

2.1 Before You Start

Before starting the installation, please check whether your **2N Access Unit M** package complies with the following list.

Package complies with the following list.	
1x	2N Access Unit M
1x	Wall holder (screwed to the device)
2x	8 mm dowel
2x	Screw with a washer
1x	Screw for fitting the device in the holder
1x	Torx key (10/20 size)
1x	Certificate of ownership
1x	Brief Manual

2.2 Mechanical Installation

2N Access Unit M is designed for surface mounting (wall, plasterboard, door frames).



Use the drilling template shown on the device box to prepare holes of the required sizes for cabling and dowels on the selected place in the required height. Feed the cables out of the pre-drilled hole.



Pull the holder downwards to remove it from the device back side.

Warning

- Do not handle the screw

ws
on
the
de
vi
ce
back
side!



Then fit the holder through the dedicated holes using the screws enclosed.



Interconnect the fed-out cables with the **2N Access Unit M** cabling. Put the device carefully on the installed holder from above downwards and fix its position on the holder carrying elements by tightening the screw from the bottom through the holder hole.

2.3 Electric Installation

2N Access Unit M can be fed either from an external 12 V / 1 A DC power supply or from a PoE 802.3af supporting LAN.

External Power Supply

Use a 12 V \pm 15 % SELV supply dimensioned to the current consumption required for the access unit power output to make your device work reliably.

Current consumption [A]	Available power output [W]
1	12

PoE Supply

2N Access Unit M is compatible with the PoE 802.3af (Class 0–12.95 W) technology and can be supplied directly from the LAN via compatible network elements. If your LAN does not support this technology, insert a PoE injector, Part No. 91378100, between **2N Access Unit M** and the nearest network element. This power supply provides **2N Access Unit M** with 12 W for its own feeding.

Combined Power Supply

2N Access Unit can be fed from an external power supply and PoE at the same time. In this configuration, the maximum supply power is available.

 **Tip**

- The external power supply can also be used a PoE switch failure backup making the unit constantly functional.

Connection to LAN

2N Access Unit M is connected to the LAN using a UTP/STP cable (category Cat-5e or higher) via the dedicated LAN connector. As the device is equipped with the Auto-MDIX function, you can use both the straight and crossed cable version.

 **Caution**

- We recommend the use of a LAN surge protection.
- We recommend the use of a shielded SSTP Ethernet cable.

Status	Power Consumption [W]							
	91611 2	91611 2-S	916114	91611 4-S	916115	916115- S	91611 6	916116-S
At relax	1.6 W	1.8 W	1.5 W	1.7 W	1.5 W	1.7 W	1.5 W	1.7 W
LED – white strip 100 %	0.12 W	0.12 W	0.12 W	0.12 W	0.12 W	0.12 W	0.12 W	0.12 W
LED – green strip 100 %	0.15 W	0.15 W	0.15 W	0.15 W	0.15 W	0.15 W	0.15 W	0.15 W
LED – red strip 100 %	0.20 W	0.20 W	0.20 W	0.20 W	0.20 W	0.20 W	0.20 W	0.20 W
LED – Bluetooth 100 %	–	–	–	–	0.06 W	0.06 W	–	–
LED – keypad backlight 100 %	–	–	–	–	–	–	0.15 W	0.15 W
Standard room temperature mode	0.14 W	0.14 W	0.14 W	0.14 W	0.14 W	0.14 W	0.14 W	0.14 W
OUT1 at maximum possible load	6 W	6 W	6 W	6 W	6 W	6 W	6 W	6 W
Audio	0.7 W	0.7 W	0.7 W	0.7 W	0.7 W	0.7 W	0.7 W	0.7 W

Description of 2N Access Unit M Cabling

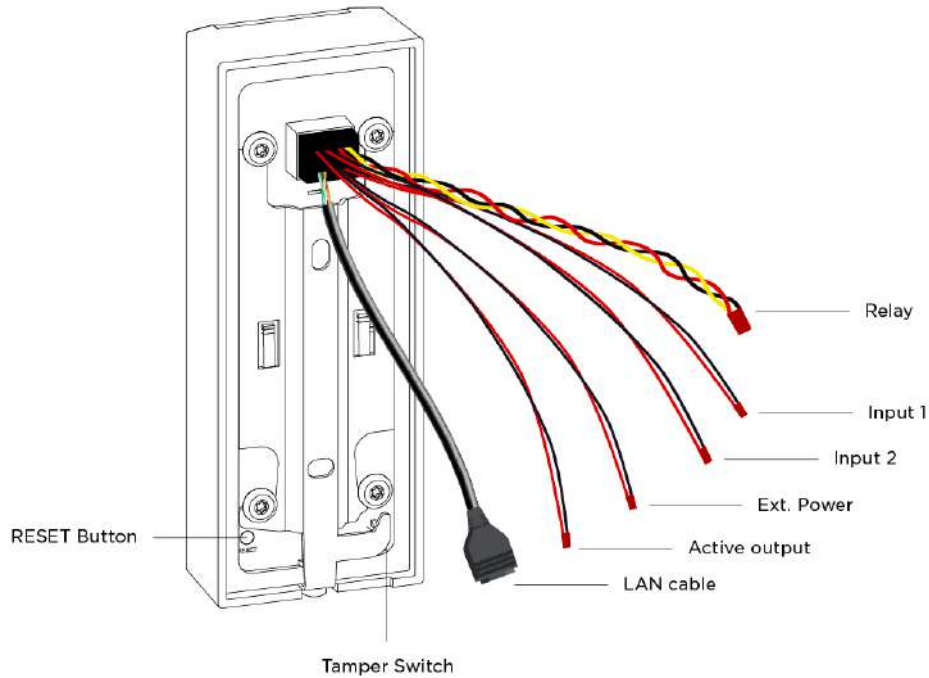

Legend	
Relay	<p>Relay cable with a 30 V / 1 A AC/DC NO/NC contact. Used for connection of non-critical devices only (lights, e.g.).</p> <ul style="list-style-type: none"> • NO – yellow • NC – red • COM – black
Input 1, 2	<p>An input cable used for the connection of a departure button, open door sensor, ESS etc. in the passive/active mode (-30 V to +30 V DC).</p> <ul style="list-style-type: none"> • OFF = open contact OR $U_{IN} > 1.5\text{ V}$ • ON = closed contact OR $U_{IN} < 1.5\text{ V}$
Ext. Power	<p>For external power supply connection (12 V / 1 A).</p>

Legend	
Active output	An active output cable for the connection of Security Relay or an electric lock: 8 to 12 V DC according to power supply (PoE: 10 V; adapter: power supply voltage minus 2 V), up to 600 mA.
LAN cable	For LAN connection (PoE 802.3af (Class –13.95 W)).
Tamper Switch	A switch that helps detect the removal of a device from the holder installed.
RESET button	RESET / FACTORY RESET button.
All the available cables are 35 cm long.	

Cable Joining

The **2N Access Unit M** signals are led by insulated wires, which are 1 cm stripped at the ends (excluding the Ethernet cable with a connector). The cables can be joined using any of the below listed methods:

- twisted joint
- terminal block
- soldering
- screw connection
- WAGO terminals
- OOP cap
- crimping using sockets

✓ Tip

- Output wiring diagram for Relay

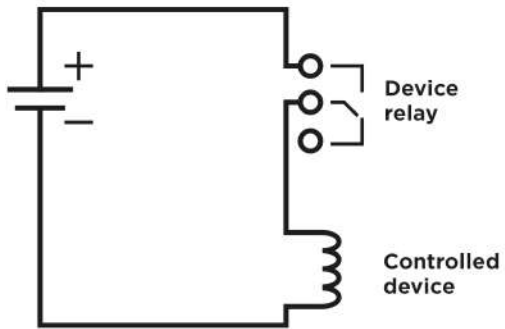

Wiring diagram for the controlled device's electric circuit closing

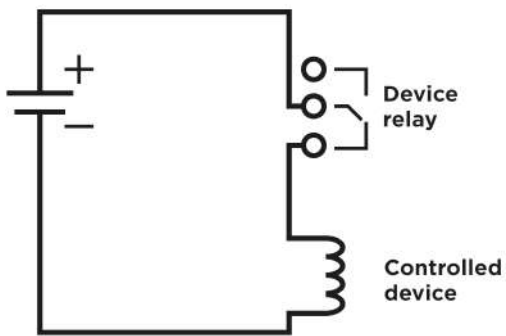

Wiring diagram for the controlled device's electric circuit opening

Tip

- Wiring Diagram for IN1, IN2 Wires in Active Mode

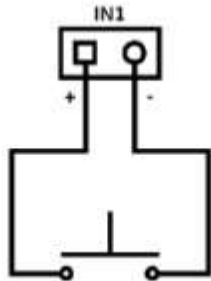

- Wiring Diagram for IN1, IN2 Wires in Passive Mode

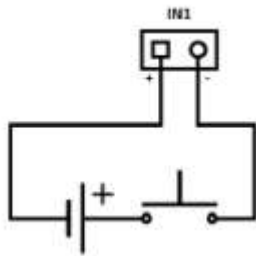
**Security**

- The 12 V output is used for lock connection. If, however, the unit (2N IP Intercom, 2N Access Unit) is installed where unauthorized tampering may happen (building envelopes), we strongly recommend that **Security Relay** (Part No. 9159010) be used for enhanced installation security.

Warning

When you connect a device containing a coil, such as a relay or an electromagnetic lock, it is necessary to protect the access system output against voltage peak while switching off the induction load. For this way of protection we recommend a diode 1 A / 1000 V (e.g., 1N4007, 1N5407, 1N5408) connected antiparallel to the device.



2.4 Extending Module Connection

The **Security Relay (Part No. 9159010)** is used for enhancing security between the access unit and the connected electric lock. It significantly enhances security of the connected electric lock as it prevents unlocking by forced opening of **2N Access Unit M**.



Function:

The **Security Relay** is a device installed between the access unit (outside the secured area) and an electric lock (inside the secured area). The **Security Relay** includes a relay that can only be activated if a valid access card is detected by the unit.

Specifications:

Passive switch: NO and NC contacts, up to 30 V / 1 A AC / DC

Switched output:

- Where the security relay is fed from the intercom, 9 to 13 V DC is available on the output depending on the power supply (PoE: 9 V; adapter: source voltage of minus 1 V) / 400 mA DC.
- Where the security relay is fed from an external power supply, 12 V / 700 mA DC is available on the output.

Dimensions: (56 x 31 x 24) mm

Weight: 20 g

Installation:

The **Security Relay** is installed onto a two-wire cable between the access unit and the electric lock inside the area to be secured (typically behind the door). The device is powered and controlled via this two-wire cable and thus can be added to an existing installation. Thanks to its compact dimensions, the device can be installed into a standard mounting box.

Connection:

Connect the **Security Relay** to the access unit as follows:

- To the Active output

Connect the electric lock to the **Security Relay** output as follows:

- To the switched output.
- To the passive output in series with an external power supply.

The device also supports a Departure button connected between the 'PB' and – Helios/2N IP intercom' terminals. Press the Departure button to activate the output for 5 seconds.

Status Signaling:

Green LED	Red LED	Status
flashing	off	Operational mode
on	off	Activated output
flashing	flashing	Programming mode – waiting for initialization
on	flashing	Error – wrong code received

Configuration:

- Connect the **Security Relay** to the properly set access unit security output. Refer to the **2N Access Unit Configuration Manual**. Make sure that one LED at least is on or flashing.
- Press and hold the **Security Relay** Reset button for 5 seconds to put the device in the programming mode (both the red and green LEDs are blinking).
- Activate the output switch using the keypad, telephone, etc. The first code sent from the intercom will be stored in the memory and considered valid. After code initialization, the **Security Relay** will pass into the operational mode (the green LED is blinking).

Caution

- In case the factory default values are reset on a device with a firmware version 2.18 or higher, it is necessary to reprogram **Security Relay** using the instructions above.

Tip

- [FAQ: 2N® Security Relay – description of the device and use with the 2N IP intercoms](#)

Tip

- [Video Tutorial: 2N IP Door Intercoms – Security Relay](#)



Sorry, the widget is not supported in this export.
But you can reach it using the following URL:

<https://www.youtube.com/watch?v=H-z-6kVyWrl&list=UUL4rQtjCnq3cT5-A9N0Xr4Q>

Connection:

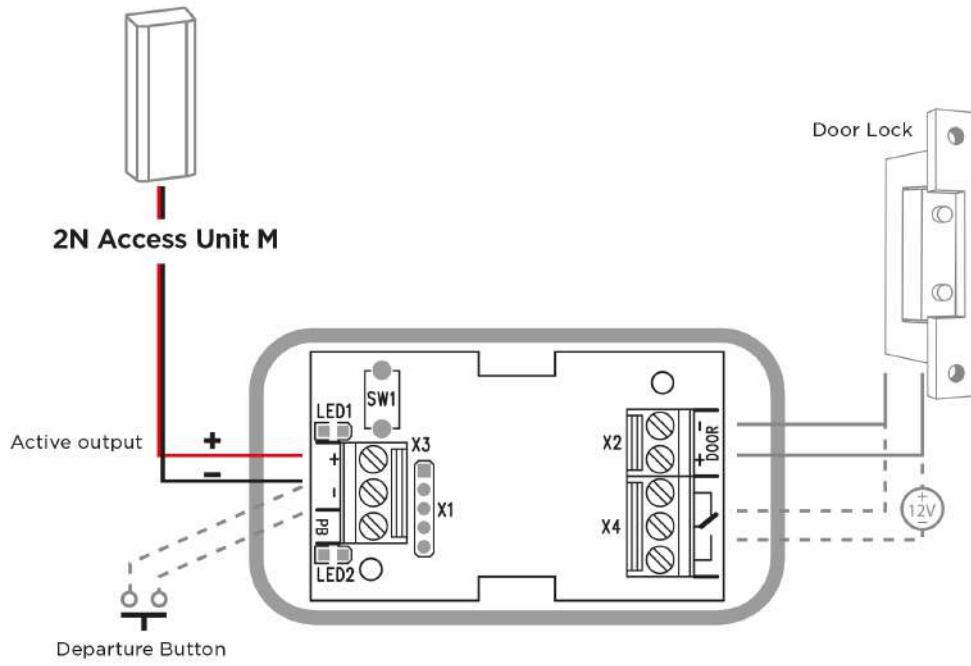

3. Detection of 2N Access Unit M using 2N® Network Scanner

2N Access Unit M is configured via the administration web server. Connect the device to the LAN IP and make sure it is properly powered.

2N® Network Scanner Description

The application helps you find the IP addresses of all the **2N Access Unit M** devices in the LAN. Download the app from the 2N web sites (www.2n.cz). Make sure that Microsoft .NET Framework 2.0 is installed for successful app installation.

1. Run the **2N® Network Scanner** installer.
2. Use the Setup Wizard for successful installation.

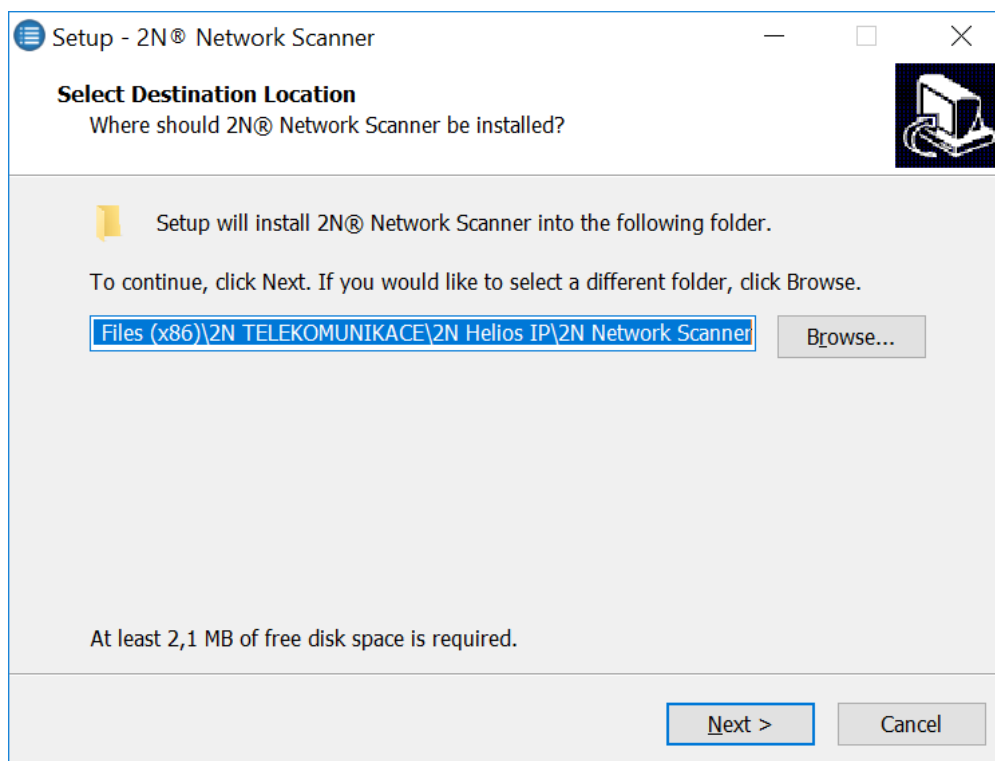

Setup Wizard of 2N® IP Network Scanner

3. Having installed **2N® IP Network Scanner**, start the application using the Microsoft Windows Start menu.

Once started, the application begins to automatically search for all the 2N devices in the LAN including their smart extensions which are DHCP/statically assigned IP addresses. All the devices are then displayed in a table

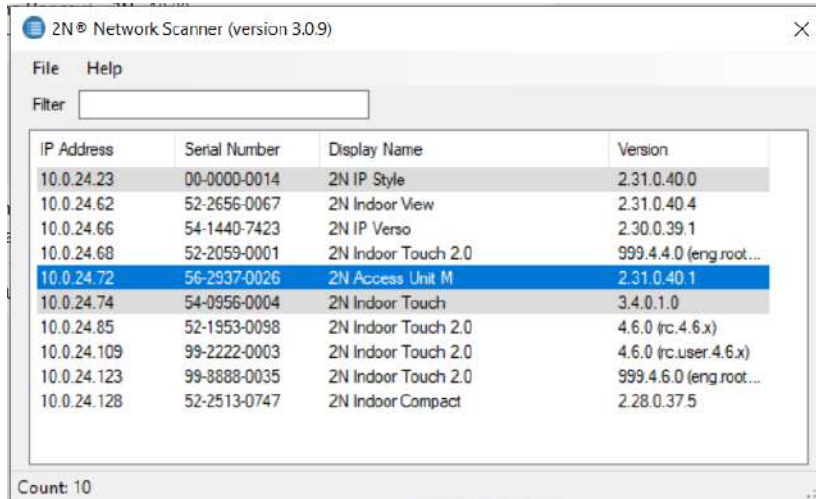

2N® Network Scanner (version 3.0.9)

File Help

Filter

IP Address	Serial Number	Display Name	Version
10.0.24.23	00-0000-0014	2N IP Style	2.31.0.40.0
10.0.24.62	52-2656-0067	2N Indoor View	2.31.0.40.4
10.0.24.66	54-1440-7423	2N IP Verso	2.30.0.39.1
10.0.24.68	52-2059-0001	2N Indoor Touch 2.0	999.4.4.0 (eng.root...
10.0.24.72	56-2937-0026	2N Access Unit M	2.31.0.40.1
10.0.24.74	54-0956-0004	2N Indoor Touch	3.4.0.1.0
10.0.24.85	52-1953-0098	2N Indoor Touch 2.0	4.6.0 (rc.4.6.x)
10.0.24.109	99-2222-0003	2N Indoor Touch 2.0	4.6.0 (rc.user.4.6.x)
10.0.24.123	99-8888-0035	2N Indoor Touch 2.0	999.4.6.0 (eng.root...
10.0.24.128	52-2513-0747	2N Indoor Compact	2.28.0.37.5

Count: 10

Window of 2N® IP Network Scanner

1. Select the **2N Access Unit M** device to be configured and right-click it. Select *Browse...* to open the **2N Access Unit M** administration web interface login window for configuration. To change the device IP address, select *Config* and enter the required static IP address or activate DHCP. The default configuration password is 2n. If the found device is grey highlighted, its IP address cannot be configured using this application. In that case, click Refresh to find the device again and check whether multicast is enabled in your network.

✓ **Tip**

- Double click the selected row in the **2N® IP Network Scanner** list to access the device web interface easily.

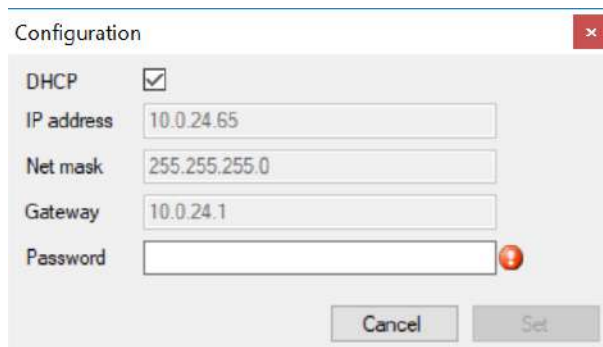

A screenshot of a 'Configuration' dialog box. The dialog has a title bar with the text 'Configuration' and a close button (X) on the right. Inside the dialog, there are five rows of configuration options:

- DHCP**: A checkbox that is checked.
- IP address**: A text input field containing '10.0.24.65'.
- Net mask**: A text input field containing '255.255.255.0'.
- Gateway**: A text input field containing '10.0.24.1'.
- Password**: An empty text input field with a red information icon (i) to its right.

At the bottom of the dialog, there are two buttons: 'Cancel' and 'Set'.

2N[®] IP Network Scanner IP Address Change

4. Factory Reset

Located in the left-hand bottom corner of device backside, the Reset button helps you reset the factory default values, restart the device, find the device IP address and switch the static/dynamic mode. The LED indicators are located on the device backside.

Press the button shortly (< 1 s) to restart the system without changing configuration.

Note

- The **2N Access Unit M** time interval between the short press of the RESET button and reconnection of the device to the network is 26 s.

IP Address Finding

Follow the instructions below to **identify the current IP address**:

- Press and hold the RESET button.
- Wait until the red and green LEDs go on simultaneously on the device and the acoustic signal  can be heard (approx. 15–35 s).
- Release the RESET button.
- The device announces the current IP address via the speaker automatically.

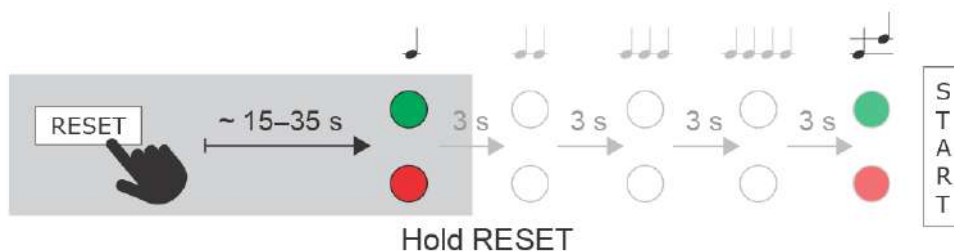



Note

- The delay between the RESET button press and the first light and sound signaling is 15–35 s depending on the 2N Access Unit model used.
 - For **2N Access Unit M** the time interval is 14 s.

Static IP Address Setting

Follow the instructions below to switch on the **Static IP address mode** (DHCP OFF):

- Press and hold the RESET button.

- Wait until the red and green LEDs go on simultaneously on the device and the acoustic signal  can be heard (approx. 15–35 s).
- Wait until the red LED goes off and the acoustic signal can be heard  (approx. for another 3 s).
- Release the RESET button.

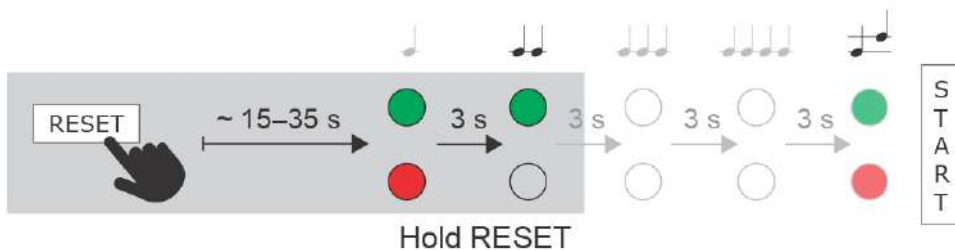

The following network parameters will be set after restart:

- IP address: 192.168.1.100
- Network mask: 255.255.255.0
- Default gateway: 192.168.1.1



Dynamic IP Address Setting

Follow the instructions below to switch on the **Static IP address mode** (DCHP ON):

- Press and hold the RESET button.
- Wait until the red and green LEDs go on simultaneously on the device and the acoustic signal  can be heard (approx. 15–35 s).
- Wait until the red LED goes off and the acoustic signal can be heard  (approx. for another 3 s).
- Wait until the green LED goes off and the red LED goes on again and the acoustic signal can be heard  (approx. for another 3 s).
- Release the RESET button.

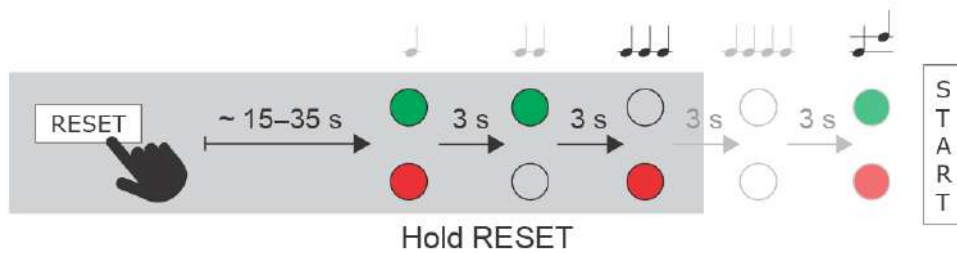

Factory Reset

Follow the instructions below to **reset the factory default values**:

- Press and hold the RESET button.
- Wait until the red and green LEDs go on simultaneously and the acoustic signal can be heard (approx. 15–35 s).
- Wait until the red LED goes off and the acoustic signal can be heard (approx. for another 3 s).
- Wait until the green LED goes off and the red LED goes on again and acoustic signal can be heard (approx. for another 3 s).
- Wait until the red LED goes off and the acoustic signal can be heard (approx. for another 3 s).
- Release the RESET button.

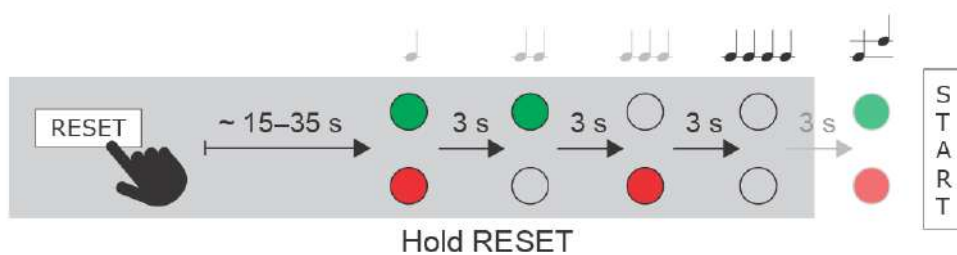

⚠ Caution

- In case the factory default values are reset on the device with a firmware version 2.18 or higher, it is necessary to reprogram **Security Relay** using the instructions from Subsection [2.4 Extending ModuleConnection](#)

5. Maintenance

If used frequently, the device, its keypad in particular, gets unavoidably dirty. Use a piece of soft cloth moistened with clean water to clean the device. You are recommended to follow the principles below while cleaning:

- Do not use aggressive detergents (such as abrasives or strong disinfectants).
- Clean the device in dry weather in order to make waste water evaporate quickly.

Warning

- Prevent water from getting inside the access unit.
- Do not use alcohol-based cleaners.

6. Status Signaling

The **2N Access Unit M** operational statuses are indicated by a light signal on the device front side. The light signal can be accompanied with an acoustic signal if set so. Refer to [5.3.3 Audio](#) of the 2N Access Unit Configuration Manual for the setting options.



The white LED light indicates the power supply and operation states.



The green LED light goes on whenever a valid PIN code is entered via the keypad or a valid RFID card is applied. Subsequently, the set switch is activated. A valid authentication is indicated by an acoustic signal if set so.



The red LED light goes on whenever an invalid PIN code is entered via the keypad or an invalid RFID card is applied. Subsequently, the set switch is not activated. An invalid authentication is indicated by an acoustic signal if set so.

✓ Tip

- Set the LED backlight level in the Hardware/Backlight section, refer to [5.3.4 Backlight](#) of the Configuration Manual for more details.

7. Technical Parameters

Audio

- **Loudspeaker:** 1 W / 8 Ω

Power Supply

- 12 V \pm 15 % / 1 A
- PoE 802.3af (Class 0–12.95 W)

Interface

- **LAN:** 10/100BASE-TX with Auto-MDIX, RJ-45 female (pigtail)
- **Recommended cabling:** Cat-5e or higher
- **Supported protocols:** DHCP opt. 66, SMTP, 802.1x, TFTP, HTTP, HTTPS, Syslog
- **Passive switch:** NO/NC contact, up to 30 V / 1 A AC/DC
- **Active switch output:** 8 to 12 V DC according to power supply (PoE: 10 V; adapter: supply voltage minus 2 V), up to 600 mA

Tamper switch: part of 2N Access Unit M

- **Inputs (Input 1,2): passive/active mode (–30 V to +30 V DC)**
 - OFF = open or $U_{in} > 1.5$ V
 - ON = short-circuited or $U_{in} < 1.5$ V

RFID card reader

- **Frequency:** 13.56 MHz & 125 kHz
- **Supported 13.56 MHz cards (card serial number is only read):**
 - ISO14443A (Mifare, DESFire)
 - PicoPass (HID iClass)
 - FeliCa
 - ST SR(IX)
 - **2N[®] Mobile Key**
- **Supported 125 kHz cards:** EM41xx

Bluetooth

- Bluetooth 5.0 in compliance with BLE (Bluetooth Low Energy)
- **RX sensitivity:** up to –94.8 dBm per 1Mbps
- **Support of higher applications:** Android 6.0 Marshmallow and higher, iOS 12.0 and higher

Mechanical properties

- **Cover:** robust ASA/PC construction material, which is also used for such car parts as lateral mirrors, radiator masks, etc. + chemically hardened 3 mm thick glass
- **Operating temperature:** –40 °C to 60 °C
- **Working relative humidity:** 10 % – 95 % (non-condensing)
- **Maximum altitude for intended use:** 2000 m a.s.l.

- **Storage temperature:** -40 °C to 70 °C
- **Dimensions:** 132 (H) x 50 (W) x 27 (D) [mm]
- **Weight:** 460 g
- **Covering level:** IP55

7.1 General Drawings

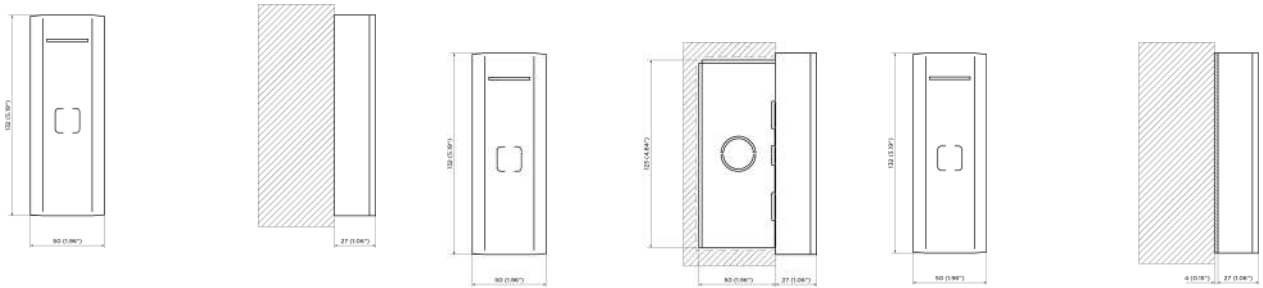

8. Supplementary Information

- [8.1 General Instructions and Cautions](#)
- [8.2 Troubleshooting](#)
- [8.3 Other Countries' Legislation](#)
- [8.4 Directives, Laws and Regulations](#)

8.1 General Instructions and Cautions

Please read this User Manual carefully before using the product. Follow all instructions and recommendations included herein.

Any use of the product that is in contradiction with the instructions provided herein may result in malfunction, damage or destruction of the product.

The manufacturer shall not be liable and responsible for any damage incurred as a result of a use of the product other than that included herein, namely undue application and disobedience of the recommendations and warnings in contradiction herewith.

Any use or connection of the product other than those included herein shall be considered undue and the manufacturer shall not be liable for any consequences arisen as a result of such misconduct.

Moreover, the manufacturer shall not be liable for any damage or destruction of the product incurred as a result of misplacement, incompetent installation and/or undue operation and use of the product in contradiction herewith.

The manufacturer assumes no responsibility for any malfunction, damage or destruction of the product caused by incompetent replacement of parts or due to the use of reproduction parts or components.

The manufacturer shall not be liable and responsible for any loss or damage incurred as a result of a natural disaster or any other unfavourable natural condition.

The manufacturer shall not be held liable for any damage of the product arising during the shipping thereof.

The manufacturer shall not make any warrant with regard to data loss or damage.

The manufacturer shall not be liable and responsible for any direct or indirect damage incurred as a result of a use of the product in contradiction herewith or a failure of the product due to a use in contradiction herewith.

All applicable legal regulations concerning the product installation and use as well as provisions of technical standards on electric installations have to be obeyed. The manufacturer shall not be liable and responsible for damage or destruction of the product or damage incurred by the consumer in case the product is used and handled contrary to the said regulations and provisions.

The consumer shall, at its own expense, obtain software protection of the product. The manufacturer shall not be held liable and responsible for any damage incurred as a result of the use of deficient or substandard security software.

The consumer shall, without delay, change the access password for the product after installation. The manufacturer shall not be held liable or responsible for any damage incurred by the consumer in connection with the use of the original password.

The manufacturer also assumes no responsibility for additional costs incurred by the consumer as a result of making calls using a line with an increased tariff.

Electric Waste and Used Battery Pack Handling



Do not place used electric devices and battery packs into municipal waste containers. An undue disposal thereof might impair the environment!

Deliver your expired electric appliances and battery packs removed from them to dedicated dumpsites or containers or give them back to the dealer or manufacturer for environmental-friendly disposal. The dealer or manufacturer shall take the product back free of charge and without requiring another purchase. Make sure that the devices to be disposed of are complete.

Do not throw battery packs into fire. Battery packs may not be taken into parts or short-circuited either.

8.2 Troubleshooting



For the most frequently asked questions refer to faq.2n.cz.

8.3 Other Countries' Legislation

<p>Thailand</p>	<div style="border: 1px solid black; padding: 10px;"> <p style="text-align: center;">เครื่องโทรคมนาคมและอุปกรณ์นี้ มีความสอดคล้องตามมาตรฐานหรือข้อกำหนดทางเทคนิคของ กสทช.</p> <hr/> <div style="text-align: center;">  <p>เครื่องวิทยุคมนาคมนี้ ได้รับยกเว้น ไม่ต้องได้รับใบอนุญาตให้มี ใช้ซึ่งเครื่องวิทยุคมนาคม หรือตั้งสถานีวิทยุคมนาคมตามประกาศ กสทช. เรื่อง เครื่องวิทยุคมนาคม และสถานีวิทยุคมนาคมที่ได้รับยกเว้นไม่ต้องได้รับใบอนุญาตวิทยุคมนาคมตามพระราชบัญญัติวิทยุคมนาคม พ.ศ. 2498</p> </div> <div style="display: flex; justify-content: space-between; align-items: center;">  <div style="text-align: right;"> <p>nans. โทรคมนาคม กำกับดูแลเพื่อประชาชน Call Center 1200 (InSWi)</p> </div> </div> </div>
------------------------	---

8.4 Directives, Laws and Regulations

2N[®] Access Unit M conforms to the following directives and regulations:

- 2014/53/EU for radio equipment
- 2011/65/EU on the restriction of the use of certain hazardous substances in electrical and electronic equipment
- 2012/19/EU on waste electrical and electronic equipment

Industry Canada

This Class A digital apparatus complies with Canadian ICES-003/NMB-003.

FCC

This equipment has been tested and found to comply with the limits for a Class A digital device, pursuant to part 15 of the FCC Rules.

NOTE: These limits are designed to provide reasonable protection against harmful interference in a residential installation. This equipment generates, uses and can radiate radio frequency

energy and, if not installed and used in accordance with the instructions, may cause harmful interference to radio communications.

However, there is no guarantee that interference will not occur in a particular installation. If this equipment does cause harmful interference to radio or television reception, which can be determined by turning the equipment off and on, the user is encouraged to try to correct the interference by one or more of the following measures:

- Reorient or relocate the receiving antenna
- Increase the separation between the equipment and receiver
- Connect the equipment into an outlet on a circuit different from that to which the receiver is connected
- Consult the dealer or an experienced radio/TV technician for help

Changes or modifications to this unit not expressly approved by the party responsible for compliance could void the user's authority to operate this equipment.

Warning

In order to ensure the full functionality and guaranteed performance, we strongly recommend that the topicality of the product / device version in use be verified as early as in the installation process. The customer hereby acknowledges that the product / device can achieve the guaranteed performance and full functionality pursuant to the manufacturer's instructions only if the latest product / device version is used after having been tested for full interoperability and not having been determined by the manufacturer as incompatible with certain versions of other products, and only in conformity with the manufacturer's instructions, guidelines or recommendations and in conjunction with suitable products and devices of other suppliers. The latest versions are available at https://www.2n.com/cs_CZ/ or can be updated via the configuration interface if the devices are adequately technically equipped. Should the customer use a product / device version other than the latest one or a version determined by the manufacturer as incompatible with certain versions of other products, or should the customer use the product / device in contradiction to the manufacturer's instructions, guidelines or recommendations or in conjunction with unsuitable products / devices of other suppliers, the customer is aware of and agrees with all functionality limitations of such a product / device if any as well as with all consequences incurred as a result thereof. Using a product / device version other than the latest one or a version determined by the manufacturer as incompatible with certain versions of other products, or using the product / device in contradiction to the manufacturer's instructions, guidelines or recommendations or in conjunction with unsuitable products / devices of other suppliers, the customer agrees that the 2N TELEKOMUNIKACE a.s. company shall not be held liable for any functionality limitation of such a product or any damage, loss or injury related to this potential functionality limitation.

